

MT



MADE
IN
GERMANY

Electromagnetic Technology



MAGNETTECHNIQUE

All our efforts are directed towards the development, production and application of electromagnetic technology throughout our extensive range of brakes and clutches. The functions, **starting, stopping, positioning and safe holding** of moving axes in machines and plant call for reliably designed and safely functioning components. With our advanced manufacturing techniques we are able to produce high quality, high-grade products, and through our continued investment we now have manufacturing plants worldwide. We have the ability to produce high volume stock parts or ones that are tailored specifically to your requirements.



Safe braking and holding



COMBISTOP

Electromagnetically actuated dual-surface spring applied DC brakes for dry operation.
... starting from page 4

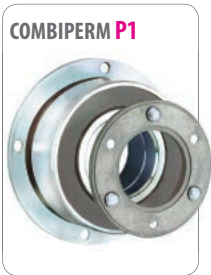

COMBIPERM

Permanent magnet brakes and clutches for dry operation.
... starting from page 16

SWITCHING, STOPPING, POSITIONING



COMBINORM

electromagnetic-actuated open-circuit operated clutches and brakes without slip rings.
... starting from page 22

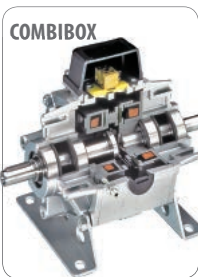

COMBIBOX

a ready to be installed electromagnetic- actuated clutch-brake-module
... starting from page 36

POWER SUPPLY / SWITCHGEAR



COMBITRON

DC-supply from the alternating voltage supply system and electronic switches for electromagnetic clutches and brakes.
... starting from page 44

COMBISTOP are electromagnetically actuated dual surface spring-applied DC brakes for dry application. The braking force is applied by the springs and released through the electromagnetic force. These brakes are successfully working in the most demanding applications and are used wherever rotating masses must be stopped or shafts need to be held in a precise position.

High quality materials together with high precision manufacturing, process inspections and functional testing guarantee reliable, safe operation.

On request we can design the **COMBISTOP** brake to your requirements, for example the brake can be supplied with pre-mounted armature and increased torque.

Please bear in mind that the rated torques are achieved after a required running-in process.

- certified to 

Program Schedule

COMBISTOP	Electromagnetically actuated dual-surface spring applied DC brakes		
Mini brakes	0.3 ... 2 Nm	page 5	COMBISTOP M
Holding brake for dynamic demands	2 ... 1,000 Nm	page 6	COMBISTOP N
Holding brake for static application	5 ... 1,500 Nm	page 6	COMBISTOP H
Holding brake for protection class IP 65	5 ... 250 Nm	page 8	COMBISTOP T
Double-brake for theatre, lift and elevators	2 x 5 ... 2 x 1,000 Nm	page 10	COMBISTOP D
Hoisting brakes, elevator brakes D8	2 x 25 ... 2 x 125 Nm	page 10	COMBISTOP L
Accessories		page 12	

Technical data

Switching times	page 15
Dimensioning / Calculation	page 50
Legend	page 51

Accessories

COMBISTOP	M	N	H	T	D	L
Friction disc		X	X		X	X
Flange	X	X	X	X	X	X
Friction disc with collar		X	X			
Dust protection ring		X	X		X	
Micro switch		X	X		X	X
Hand release	X	X	X	X		X
Terminal box		X	X	X	X	X

COMBISTOP

stands for MINI Brake, the small compact solution with torques up to 2 Nm. The brake is characterized by a particular compact construction, it is designed for small loads and holding functions without torque adjustment and adjustability and available with or without hand release.

Range of application: e.g. general machine building, small-power motors, automation technique, apparatus engineering.



COMBISTOP M
0B08110... without hand release

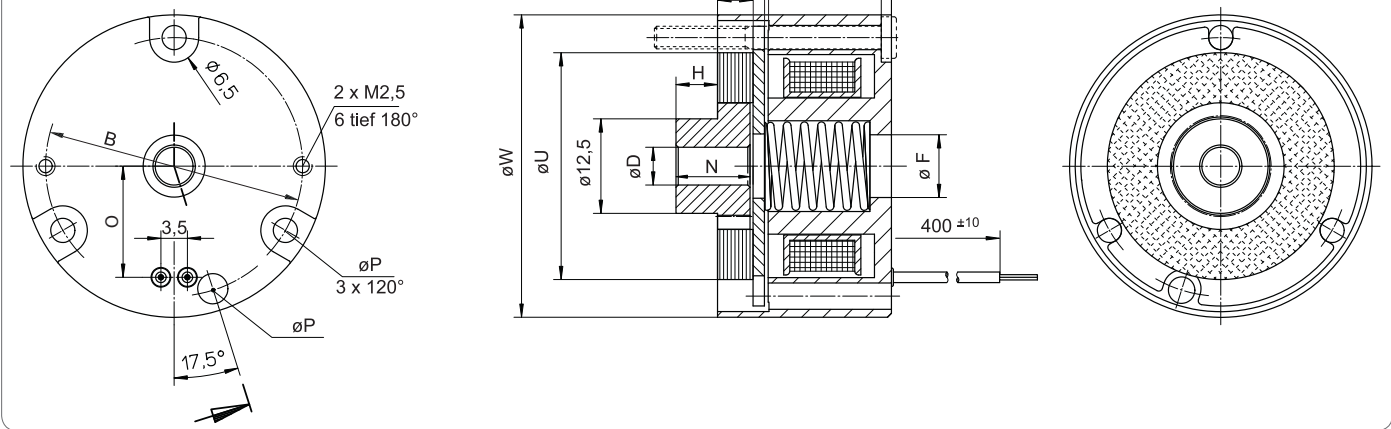

Size	$\frac{M_{2N}^{1)}$ [Nm]	$\frac{P_{20}}$ [W]	A	B	D	F	G	H	K	N	O	P	T	U	V	W	X	a_1	b_1	c	e	g	$m^{3)}$	α°	weight [kg]
0B08	0.3	6		34	5	8.3	23	5.5		9.8	14.7	3.5		30	40	0.1						4.7		7	0.15
0008	0.5-2	11-15	59.5	52	10 ³⁾	14	29.5	0.5-1	4.5	16	18	4.3	5	43.5	26	59.5	0.15	41	36.5	2	7	5.5	0.8	7	0.4

All dimensions in mm keyway according to DIN 6885/1 according to VDE 0580, isolation class „B“ ¹⁾ rated torque after running in process ²⁾ bore tolerance max ϕ 10 mm H7, otherwise H8 ³⁾ Mounting dimension „m“ with attracted armature

COMBISTOP M
0008110... without hand release
0008130... with hand release

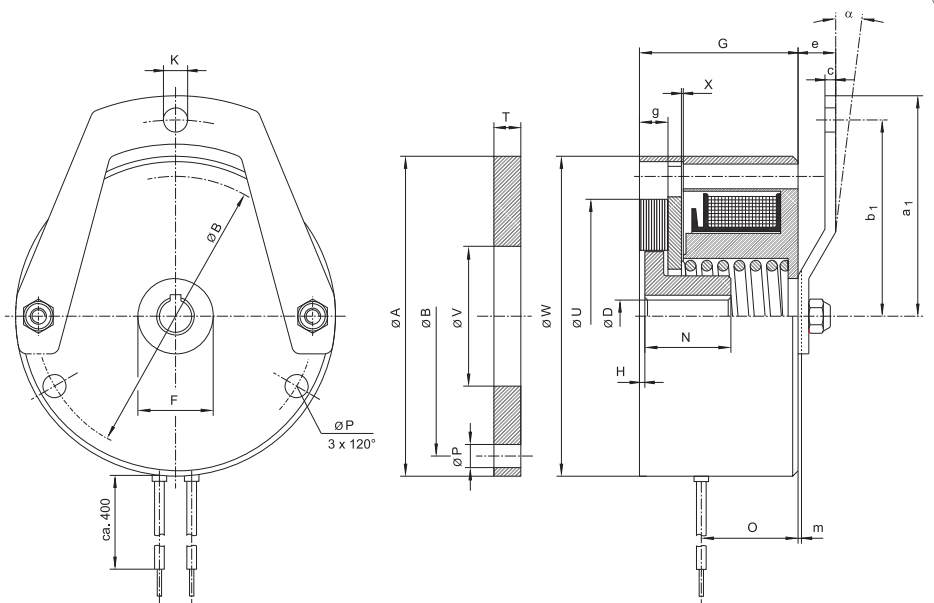

Accessories **COMBISTOP M**
• flange

COMBISTOP N and H

COMBISTOP N and H are the standard series of dual-surface spring-applied brakes in two designs:

- dynamic applications with continuous stress
- static applications with short-term stress

COMBISTOP N
COMBISTOP H

COMBISTOP N: Rated torque in the range 5 ... 1000 Nm
- designed for dynamic applications with regular brake applications at high speed!

Range of application: e.g. brake motors, geared brake motors, wind energy plants, refrigerated warehouses

Option:

- Cold Climate Version CCV (-40 ... +60 °C)
- ISO-class F + H

Accessories **COMBISTOP N**

- Friction disc
- Flange
- Friction disc with collar (up to size 06)
- Dust protection ring
- Micro switch



COMBISTOP

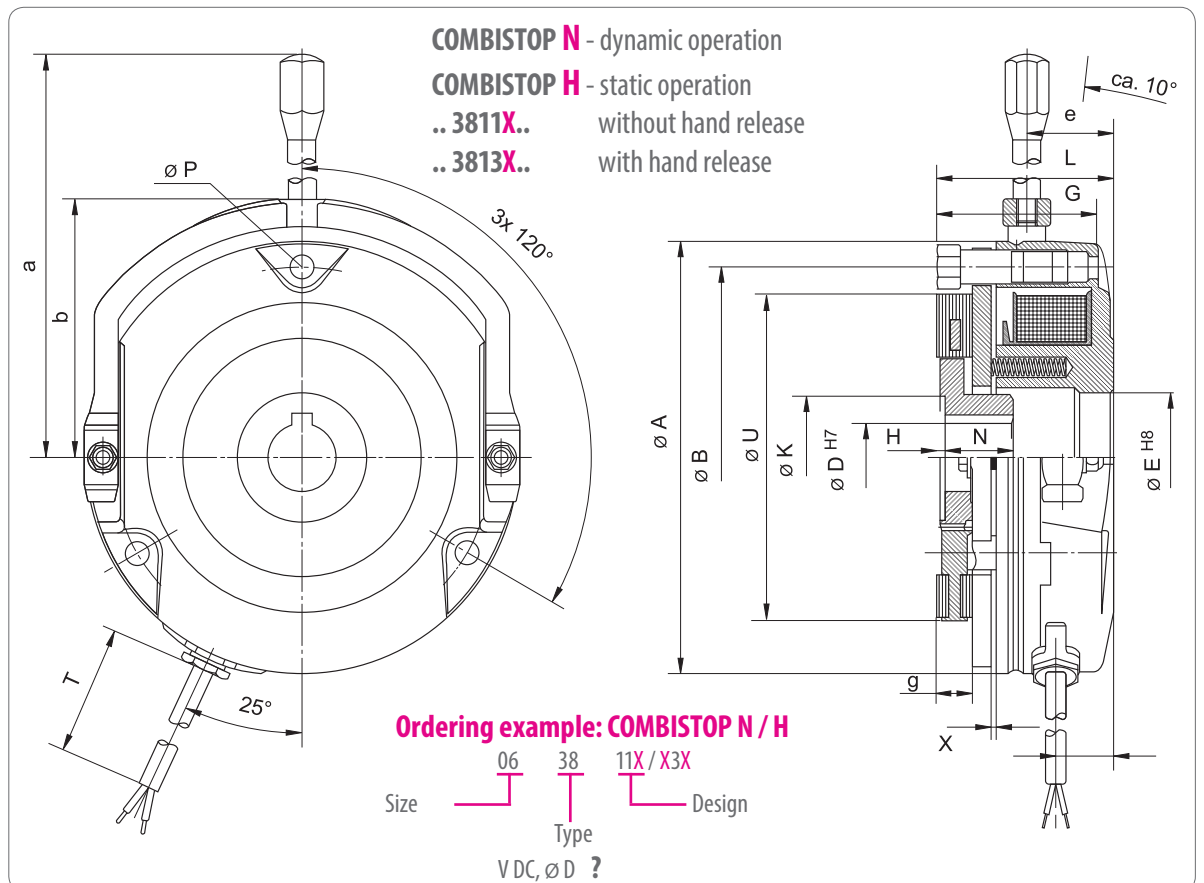

Size	Version „N“		Version „H“		A	B	H7 ØD max.	E	G	H	K	L	N	O	P	T	U	X	a	b	e	g	weight kg
	M _{2N} ¹⁾	P ₂₀	M _{2N} ¹⁾	P ₂₀																			
	Nm	W	Nm	W																			
02	5	25	7.5	25	85	72	15**	22	34.2	1-1.5	22	37.7	18	11.5	3x4.5	500	60	0.2	105.5	53.5	23	7.5	1
03	10	30	15	30	102	90	20	32	37.2	2-2.5	31	41.7	20	13	3x5.5	500	77	0.2	113	62	25.5	8	1.5
04	20	30	30	30	127	112	25	38	47.2	2-2.5	37	51.7	20	16.5	3x6.5	500	96	0.2	128	76	26.2	10.5	3
05	36	48	50	48	147	132	30	42	52.7	2.5-3	42	57.7	25	18.5	3x6.5	500	115	0.2	168	86	30.5	12	4.5
06	70	62	90	75	164	145	35**	47	59.8	2.5-3	42	68.8	30	20	3x9	500	115	0.3	176	96	39.5	12	7
07	100	65	150	90	190	170	45	62	68	3	57	75.5	30	21.5	3x9	750	149	0.3	225	115	41	14	10
08	150	75	225	90	218	196	60	78	80	4.5	57/76*	*87.4	35	27	3x9	750	175	0.4	235	125	46.5	16	16
09	250	80	375	115	253	230	60	97	88.2	5	76	101.7	40	28	3x11	750	206	0.4	256	146	56	18	26
10	500	130	750	180	307	278	75	120	98.8	9.5	92	110.8	50	25	6x11	750	252	0.5	335	175	59	22	39
11	1,000	180	1,500	280	363	325	90	140	122.1	-	-	134.5	100	30.5	6x13	1,000	300	0.6	***	***	***	30	80

All dimensions in mm keyway according to DIN 6885/1 Standard voltage 24 / 105 / 180 / 205 V DC according to VDE 0580, isolation class „B“, 100% on time, Type of protection IP40, with dust protection ring IP44
¹⁾ rated torque after running in process * hub bore > ø 45 ** keyway according to DIN 6885/3 *** mech. release with hexagon screw

COMBISTOP H: Rated torque in the range 7,5... 1500 Nm - designed for static applications, i.e. braking from low speeds and secure holding of loads!

Range of application: e.g. electronically controlled or regulated drives, wind energy plants, refrigerated warehouses

Accessories COMBISTOP H

- Friction disc
- Flange
- Friction disc with collar (up to size 06)
- Dust protection ring
- Micro switch



A brake design which are always used whenever the application puts higher demands on the protection class.

COMBISTOP T: the **IP 65**-brake with identical hole circle such as **COMBISTOP N** and **H**, optionally completely closed on the backside or prepared for the attachment of tachogenerators or shaft sealing ring.

Range of application: e.g. general machine building, crane construction, ship gear, wind energy plants, refrigerated warehouses

COMBISTOP T

- ..28G10** standard version without hand release
- ..28G20** standard version with hand release
- ..28G1T** for tachogenerators without hand release
- ..28G2T** for tachogenerators with hand release
- ..28G1W** for shaft sealing ring without hand release
- ..28G2W** for shaft sealing ring with hand release

Size	M _{2N} ¹⁾ [Nm]	P ₂₀ [W]	øA ₁	øA h8 H8	øB	C	øD max.	øE	øE ₁	øF	øG	H	øK	L	M	M ₁	N	O
02	5	25	102	98	72	34	15**	50	85	94.5	88	1-1.5	22	39	2.4	88 x 3	18	11
03	10	30	123	118	90	37	20	64	102	116	109.5	2-2.5	31	42.8	2.4	110 x 3	20	12.5
04	20	30	148	143	112	47	25	80	127	138.5	132	2-2.5	37	52.8	2.4	132 x 3	20	16
05	36	48	170	165	132	51.5	30	102	147	158.5	152	2.5-3	42	58.3	2.4	152 x 3	25	17
06	70	62	186	180	145	60	35**	115	164	176.5	170	2.5-3	42	68.8	2.4	170 x 3	30	20
07	100	65	216	210	170	68	45	144	193	200.5	196	2.0	57	74.2	3.5	196 x 4	30	20
08	150	75	246	240	196	77	60	160	217	235.5	225	4.5	57 76*	88	3.2	225 x 4	35	25
09	250	80	280	276	230	86	60	180	254	272	260	5.0	76	102	3.5	260 x 5	40	33

Size	øP	øP ₁	øP ₂	R	T	øV	X	a ₁	b ₁	ød	e	sw	øf	øg	s	k	L ₁	I
02	4.5	8	M4	0.5	6	37	0.2	105.5	53.5	8	22.5	11	22	34	4 x M4	10	36.5	44
03	5.6	10	M5	1.5	7	48	0.2	114	62	8	24	11	32	40	4 x M5	12	40.1	52
04	6.5	11	M6	1.5	9	60	0.2	128	76	8	25.7	11	38	54	4 x M5	12	50.1	66
05	6.5	11	M6	2	9	70	0.2	166	86	10	28	14	42	64	4 x M5	12	56.1	76
06	9	15	M8	2	11	70	0.3	176	96	10	40	14	47	75	4 x M5	12	65.5	88
07	9	15	M8	3.0	12	75	0.3	225	115	14	40	17	62	85	4 x M6	15	73	100
08	9	15	M8	3.5	14	95	0.4	235	125	14	45	17	78	100	4 x M6	15	86	120
09	11	18	M10	4.0	15	95	0.5	256	145	14	40	17	78	110	4 x M6	15	101	130

see dimensions diagram 28.M01-3-0031

All dimensions in mm keyway according to DIN 6885/1 standard voltage 24/105/180/205 V DC according to VDE 0580, ISO-class „B“, 100% on time,
¹⁾ rated torque after running in process * hub bore > ø 45 ** keyway according to DIN 6885/3, **Attention:** under the fixing screws are sealing washer (DIN7603) have to be used

COMBISTOP

Option: • Cold Climate Version CCV (-40 ... +60 °C) • ISO-class F + H

Accessories **COMBISTOP T**

- Flange
- Hand release
- Shaft sealing ring

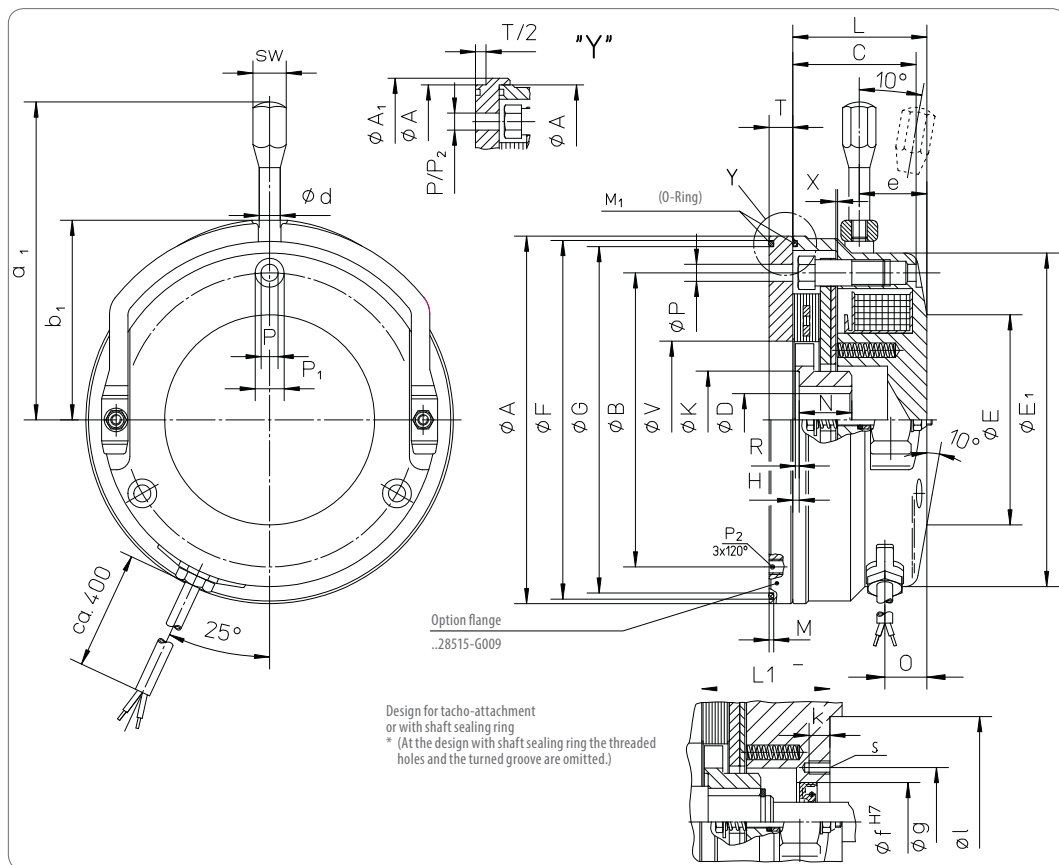

Ordering example: COMBISTOP T

Size	06	28	GXX	Design
	Type			
	VDC, Ø D ?			

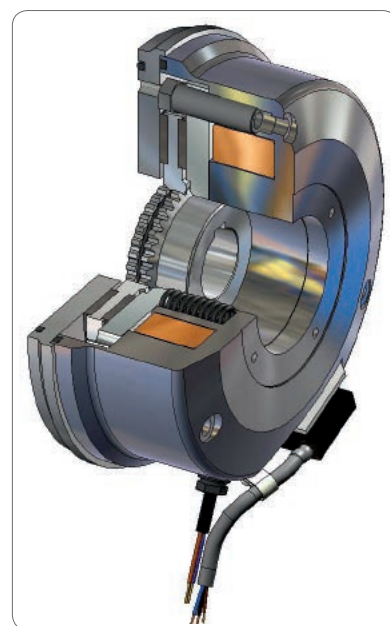

COMBISTOP D stands for **double safety** and covers a series of double brakes, which is prepared for tasks with redundant brake circuits.

The mechanical construction with two completely independent fail-safe spring-applied brakes meets the requirements according to DIN 56950 (BGV C1).

The brakes are supplied ex factory, ready for attachment with preadjusted air gaps.

Extensive constructional measures reduce the switching and running noises to a minimum..

Range of application: e.g. theatre equipment, passenger and freight elevators

Option: ISO class F

Size	$M_{2N}^{(1)}$ (Nm stat)	P_{20} (W)	A	B	C	1 & 2 D (max)	E	F	H	L_1	L_2	M	N_1	N_2	R_1	T	X	a	b
02	2x5	2x25	85	72	22	15**	22	36	91.2	9.5	1.5	18	27.5	13	8	500	0.2	105.5	53.5
03	2x10	2x30	102	90	32	20	31	48	106	12.5	2.5	20	34	17	10	500	0.2	114	62
04	2x20	2x30	127	112	38	25	37	60	121	12.5	2.5	20	39	23	10	500	0.2	128	76
05	2x36	2x48	147	132	42	30	42	70	135	14	3	25	41	21	11	500	0.2	168	86
06	2x70	2x62	164	145	47	35**	42	70	157	16	3	30	45	20	13	500	0.3	176	96
07	2x100	2x65	190	170	62	45	57	75	180	18.5	3	30	59	37	15	750	0.3	225	115
08	2x150	2x75	218	196	78	60	57/76*	100	193	19.5	5	35	55	33	14.5	750	0.3	235	125
09	2x250	2x80	254	230	97	60	76	100	224	22	5.5	40	65	45	16.5	750	0.3	256	146
10	2x500	2x130	306	278	120	75	92	120	241	27	10	50	63	36	17	750	0.4	335	175
11	2x1,000	2x180					upon request												

All dimensions in mm keyway according to DIN 6885/1 standard voltage 24 / 105 / 180 / 205 V DC according to VDE 0580, ISO-class „B“, 100% on time,
¹⁾ rated torque after running in process * hub bore > ø 45 **keyway according to DIN 6885/3

COMBISTOP L as special development for the elevator industry the dual-circuit spring-applied fail-safe brake fulfills the valid requirements of EN 81 respectively TRA 227.

The brake series, tested by the technical inspection authority, contains two mechanical braking circuits and offers compact dimensions and easy mounting.

Range of application: e.g. passenger and freight elevators, theatre equipment

Option: ISO class F + H

Accessory **COMBISTOP L**

- Friction disc
- Flange
- Micro switch

Size	$2 \times M_{2N}^{(1)}$ (Nm stat.)	P_{20} (W)	A			B			C			D ^{H7}			E			F			G			H		L		N	O	X_1
			A	B	C	D ^{H7}	E	F	G	D8230	D8630	D8230	D8630	N	O	X_1														
05	25	60	154	146	132	30	42	65	147	3	3	53.8	54.3	25	19.5	0.3														
07	50	65	203	188	170	40	57	65	190	3	3	74.3	74.3	30	20	0.4														
09	125	75	268	230	230	60	76	101	254	5	5	98.7	98.7	40	20	0.5														

Size	a	b	d	e		l	m	P_1^* ISO 4762	P_2^* ISO 4762	P_3^* ISO 4762	$2 \times X_V$ D8630	SW	α°	δ°
				D8230	D8630									
05	169	89	10	34.8	35.3	2.5	1.2	M6x65	M6x10	M5x40	0.15	14	10	28
07	225	115	14	33.5	33.5	2.5	1.3	M8x80	M8x12	M6x50	0.20	17	10	25
09	255	145	14	65.7	65.7	3.0	1.4	M10x100	M10x16	M8x75	0.25	17	10	25

All dimensions in mm keyway according to DIN 6885/1 standard voltage 24 / 105 / 180 / 205 V DC according to VDE 0580 ISO-class „B“ 100% on time,
¹⁾ rated torque after running in process * hub bore > ø 45 **keyway according to DIN 6885/3 see dimension diagram D8.M01-4-0707

Accessories **COMBISTOP D**

- Friction disc
- Micro switch
- Dust protection ring
- Flange
- Friction disc with collar (up to size 06)

Ordering example: **COMBISTOP D**

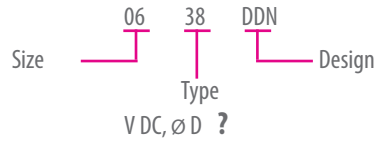

Fastening Screws							
e_2	d_1	d_2	m	Z 1/2/3	Z_1	Z_2	Z_3
22.5	34.6	39	0.8	M4	3x8.8	3x8.8	3x8.8
27	37.7	47.5	1	M5	3x8.8	3x8.8	3x8.8
31	47.8	54.4	1.4	M6	3x8.8	3x8.8	3x8.8
33	53.4	55.9	1.5	M6	3x10.9	3x8.8	3x8.8
36	60.3	64.5	1.8	M8	3x10.9	3x8.8	3x8.8
45	68.8	77.6	2	M8	6x8.8	3x8.8	3x8.8
50	80.8	82.7	2	M8	6x10.9	3x10.9	3x10.9
56	89.4	95.4	2.3	M10	6x8.8	3x10.9	3x10.9
61	99.5	105	2.7	M10	6x10.9	6x8.8	3x8.8

see dimension diagram 38.003-3-0714

COMBISTOP D .. 38DDN...

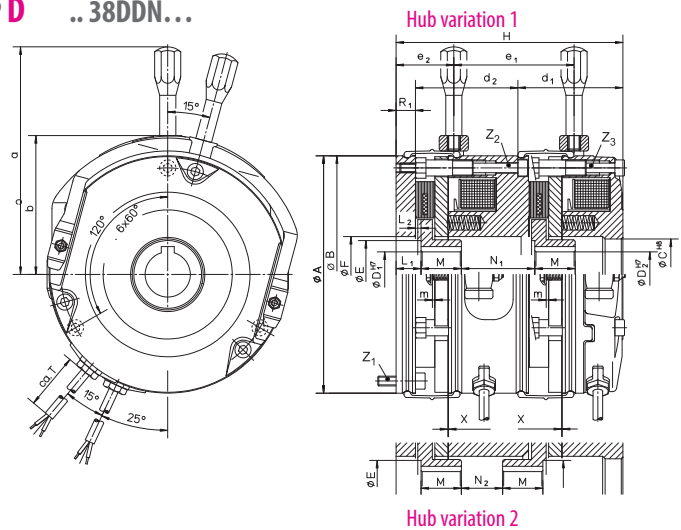

COMBISTOP L .. D8230... with hand release COMBISTOP L .. D8630... with hand release, with backlash-free hub-lining-system

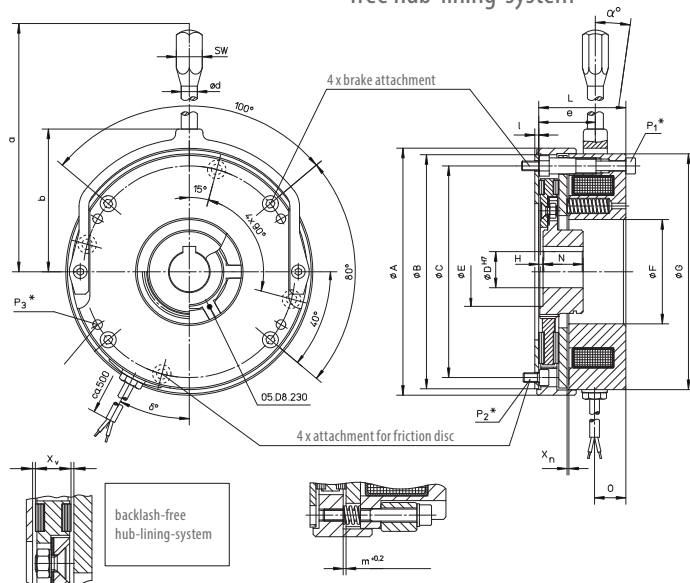

Ordering example: **COMBISTOP L**

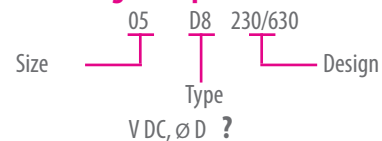

To adapt the spring-applied brakes to the various requirements of different applications an extensive program with a wide range of accessories is available. Please contact us to discuss your requirements. To ensure correct selection we have on hand an experienced team of application engineers to assist you in all aspects of selection, enabling you to get the optimum solution.

Accessory - dust protection ring (IP44) .. 08550-0009

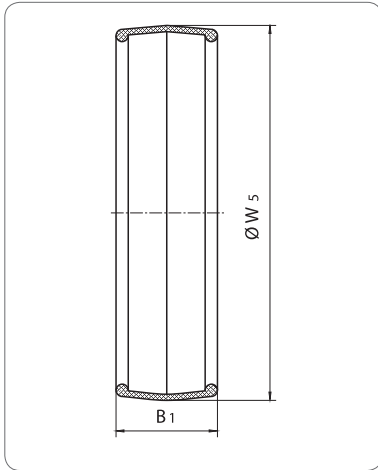

To protect the friction surfaces against dust or dripping water different sizes of dust protection rings are available. When fitting the **COMBISTOP** with a dust protection ring the friction disc **xx08515-xxxx** must be used on the motor side. This friction disc will be supplied nitrated and is especially designed to hold the dust protection ring.

		Article number xx08550-0009									
Size		02	03	04	05	06	07	08	09	10	11
B_1		22.5	25	33	33.5	38.5	45.5	49	54.5	63	upon request!
W_5		86	103	129	149	167	195	222	259	310	

all dimensions in mm

Accessory - micro switch

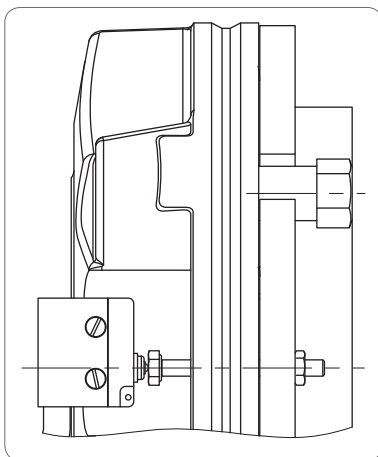

The use of **COMBISTOP** can be fitted with a micro switch for monitoring the functions and the wear. The use of **COMBISTOP** with micro switch is particularly sensible for braking motors on hoisting gears that are operated with frequency inverters.

Friction discs and flanges provide suitable counter-rotation surfaces for the spring applied brakes and are available in hardened and rustproof design.

Accessory - friction discs ..08451...

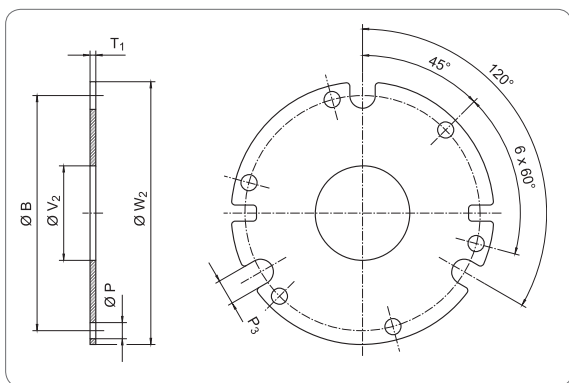

		Article number xx08451-xxxx									
Size		02	03	04	05	06	07	08	09	10	11
B		72	90	112	132	145	170	196	230	278	
P		4.5	5.5	6.5	6.5	9	9	9	11	11	
T ₁		1.5	2	2	2	2.5	2.5	2.5	3	4	
P ₃		7.5	8.5	10.5	10.5	14.5	14.5	14.5	17	17	
V ₂		27	35.5	42.5	47	51	85	100	105	198	
W ₂		82	98	123	146	157	188	214	250	302	
Weight [kg]		0.05	0.10	0.15	0.22	0.30	0.40	0.64	0.93	1.50	

All dimensions in mm

Accessory - friction discs with collar ..08515...

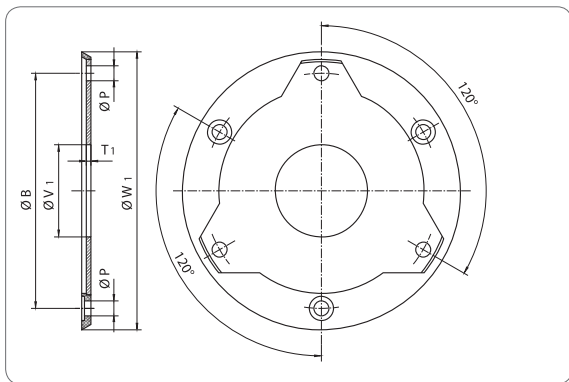

		Article number xx08515-xxxx									
Size		02	03	04	05	06	07	08	09	10	11
B		72	90	112	132	145					
P		4.5	5.5	6.5	6.5	9					
T ₁		1.5	2	2	2	2.5					
V ₁		27	35.5	42.5	47	51					
W ₁		88.5	106	132	153	171					
Weight [kg]		0.05	0.10	0.15	0.25	0.35					

All dimensions in mm

Accessory - flange with collar for dust protection ring ..38510...

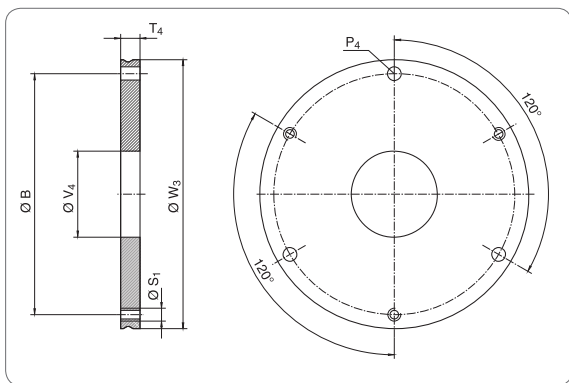

		Article number xx38510-0009										
Size		00	02	03	04	05	06	07	08	09	10	11
B		52	72	90	112	132	145	170	196	230	278	325
P ₄			3x4.3	3x5.3	3x6.4	3x6.4	3x9	3x9	3x9	3x11	6x11	6x13
S ₁			3xM4	3xM5	3xM6	3xM6	3xM8	3xM8	3xM8	3xM10	6xM10	6xM12
T ₄		5	6	7	9	9	11	11	11	11	12.5	20
V ₄		26	20	30	40	45	55	65	75	90	120	160
W ₃		60	83	100	125	145	163	190	217	254	306	363
Weight [kg]		0.08	0.20	0.35	0.75	1	1.50	2.10	2.70	3.70	5.90	12.7

All dimensions in mm

max. speed

Size	Operating-stop [rpm]	max. speed		Type M, T [10 ⁻³ kgm ²]	J Type N, H, D ¹⁾ [10 ⁻³ kgm ²]	g _{min} min. lining thickness [mm]	X _n max. air gap [mm]
		Type M, T emergency stop [rpm]	Typ N, H, D Notbremsung [rpm]				
00	3,000	6,000	-	0.001	-	-	-
02	3,000	6,000	6,000	0.025	0.025	5.5	0.4
03	3,000	6,000	6,000	0.072	0.072	6.5	0.5
04	3,000	6,000	6,000	0.136	0.136	8	0.6
05	3,000	5,000	5,000	0.35	0.35	10	0.6
06	3,000	5,000	5,000	0.56	0.56	10	1
07	3,000	4,500	4,500	1.57	1.57	10	1
08	3,000	3,500	3,500	5.92	5.92	11	1.2
09	1,500	3,000	3,000	7.38	7.38	12	1.2
10	1,500	3,000	3,000	20.54	20.54	14	1.5
11	1,500	3,000	2,000		180.7	28	1.5

g_{min} min. permissible lining thickness [mm]

¹⁾ for brake type D use for calculation 2 x [J]

Friction switching frequency Type M, T

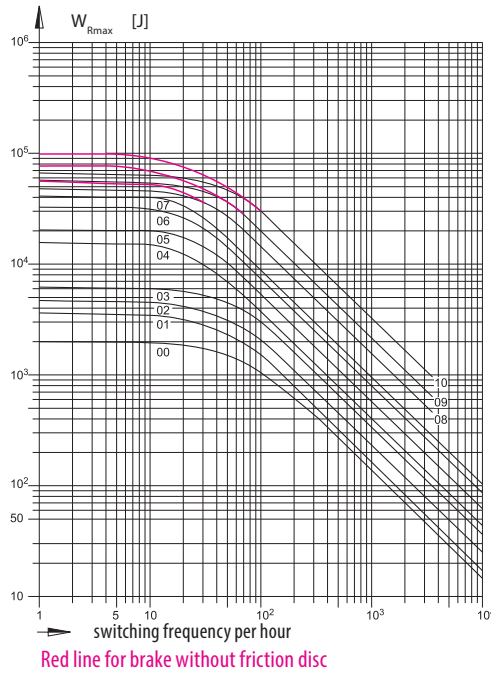

Friction switching frequency Type N, H, D

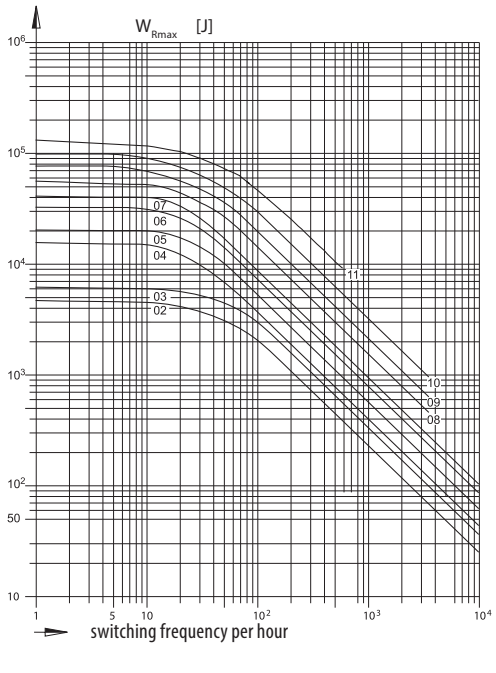

Permissible friction W_{Rmax} [J] dependence on the switching frequency

Valid only for the stated revolutions per minute

type **M, T, N, H, D** size 00 ... 07 - 3000 rpm

type **T, N, H, D** size 08 ... 11 - 1500 rpm

The values for W_{Rmax} are valid for standard brakes and a second friction surface of casting. Depending on application these values may be exceeded or remained under. Rustfree friction discs, or speeds higher than specified in the diagram, reduce the permissible friction work considerably. If the rated torque of the brake is reduced by turning the adjustment ring (optional) the permissible friction work increases.

Switching cycles and switching times

Size	switching cycles				AC-switching						DC-switching			
	SC_1 [rpm]		SC_2 [rpm]		t_2 [ms]		$t_{1\sim}$ [ms]		$t_{1\sim}$ [ms]		$t_{11=}$ [ms]		$t_{1=}$ [ms]	
	M, T	N, H, D	M, T	N, H, D	M, T	N, H, D	M, T	N, H, D	M, T	N, H, D	M, T	N, H, D	M, T	N, H, D
00	70		140		35		60		100		12		25	
02	60	60	120	120	40	40	40	70	90	100	10	10	20	20
03	40	60	75	75	60	55	80	100	140	150	15	15	30	30
04	40	60	75	75	100	90	140	180	200	200	20	25	50	50
05	25	25	50	50	120	110	180	220	240	240	25	25	55	55
06	5	5	10	10	240	240	200	260	330	330	25	25	90	90
07	5	5	10	10	240	220	400	400	650	650	50	40	150	120
08	5	5	10	10	300	320	700	700	900	900	60	50	180	180
09	2	2	5	5	350	350	900	900	1200	1,200	60	60	220	220
10	1	2	3	3	350	400	1,400	1,400	1800	2,000	60	100	250	300
11		1		2		750		3,100		3,500		450		1,000

COMBISTOP Typs: M, T, N, H, D (see page 4)

SC_1 applicable for rectifiers:

0291010-CE07

0291020-CE07

0291010-CEMV

SC_2 applicable for rectifiers:

0491010-CE07

0491020-CE07

0591010-CE09

0691010-CE09

SC maximal permissible switching cycle

at DC-side switching, 100% on time and max. operating temperature of 80 °C.

[rpm]

t_1 engaging time

time from disconnecting the current to attaining the rated torque.

[ms]

t_{11} engagement delay time

time from disconnecting the current to the rise of the torque.

[ms]

t_2 release time

time from connecting the current to the beginning of torque decrease.

[ms]

The designation of the switching times corresponds to DIN VDE 580

Switching cycles COMBISTOP with POWERBOX

Size	t_2 [ms]	max. air gap [mm]	switching cycles [rpm]
02	20	1.0	55
03	35	1.8	40
04	50	2.1	40
05	60	3.0	25
06	120	3.0	5
07	120	3.5	5
08	150	3.0	5
09	170	3.5	2
10*	180	4.5	1

* Continuous operation only permissible at 45 °C!

230 V AC input voltage and 105 V DC coil

Switching times apply to rated air gap X

Switching cycles apply to DC-side switching

Power supply

COMBISTOP requires DC voltage for operation. For the power supply different half-wave or full-wave rectifiers of the series COMBITRON 98 are available for DC or AC-side switching, which, depending on the type, are suitable for connection voltages up to 720 V AC rated voltage.

The switching characteristics and functions of the COMBISTOP can be optimized through the rapid switch rectifier COMBITRON 98..

COMBIPERM are electromagnetically released permanent magnet brakes and clutches for dry operation whose flux is generated by permanent magnets. This effect permits the connection of shafts in voltage free condition or the safe deceleration of masses.

You find possible shaft diameters in the "Bore Table" on page 51.

On request we adapt **COMBIPERM** to your constructional and electrical requirements.

Program Schedule

COMBIPERM quiescent-current operated brakes and clutches

Holding brake with Emergency-Stop-function	0.4 ... 145 Nm	page 17	COMBIPERM P1
Clutch quiescent-current operated	6 ... 120 Nm	page 19	COMBIPERM PC

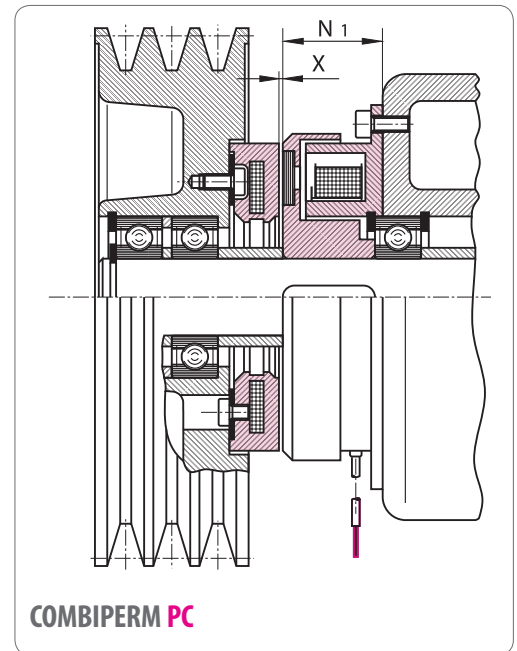
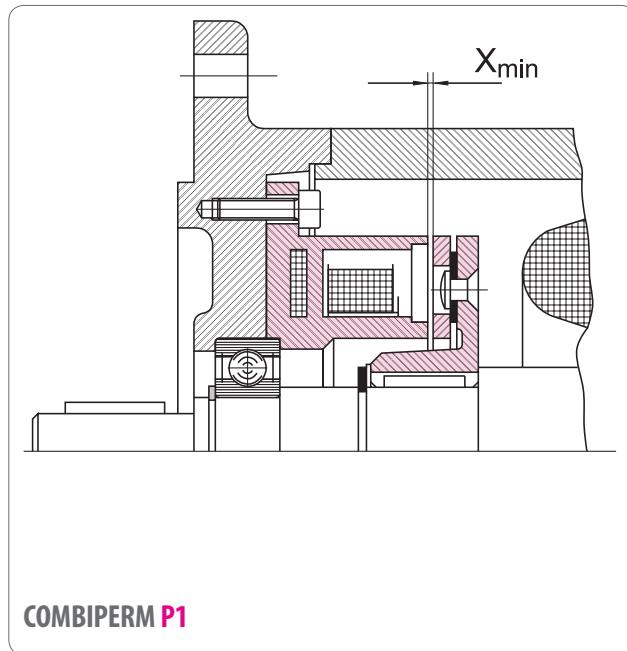

Technical Data

Switching times	page 20
Moments of inertia, friction, -rating	page 21
Dimensioning / Calculation	page 50
Bore table COMBINORM / COMBIPERM	page 51

COMBIPERM

COMBIPERM P1 first choice for your servomotor

are powerful permanent magnet brakes with frictionally engaged, backlash-free effect. Rare earth magnets create a force field, which is cancelled by the counter-pole magnet coil (opened) in current-supplied condition and in combination with the membrane spring on the armature it ensures a residual torque-free separation independent of the installation position.

COMBIPERM P1 are designed for rated operating voltage 24 V DC according to ISO class F (max. 155 °C) and ensure a safe operation within a wide range of temperatures. On request versions in other operating voltages are available.

- certified to 



Range of application: e.g. machine building, medical technology, industrial robots, servo-drives

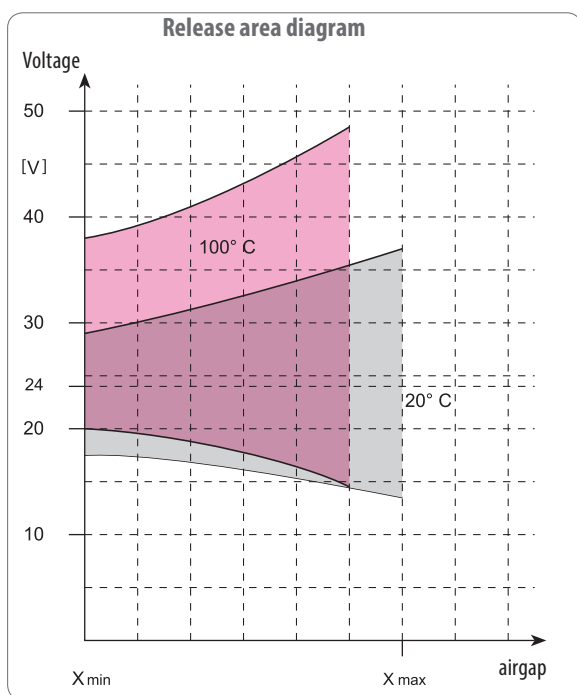

Please bear in mind

- that magnetic materials within the direct surroundings can weaken the torque, reduce maximal air gaps and lead to a shifting of the release range.
- that the rated torques are achieved after a required running-in process (please see instruction manual).
- that the torques become less at higher speeds

Ordering example: COMBIPERM P1

Size 06 Type P1 Design 130
 V DC, $\varnothing d_{30}$?

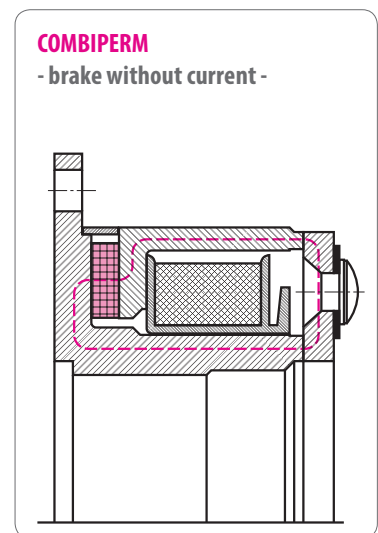
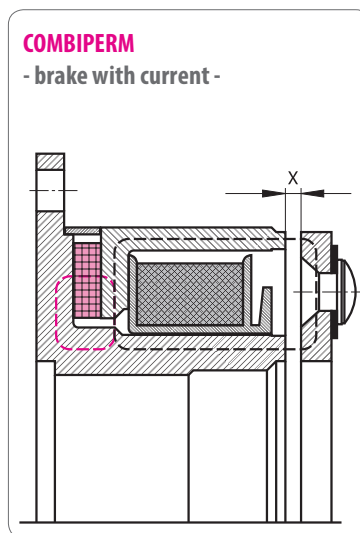

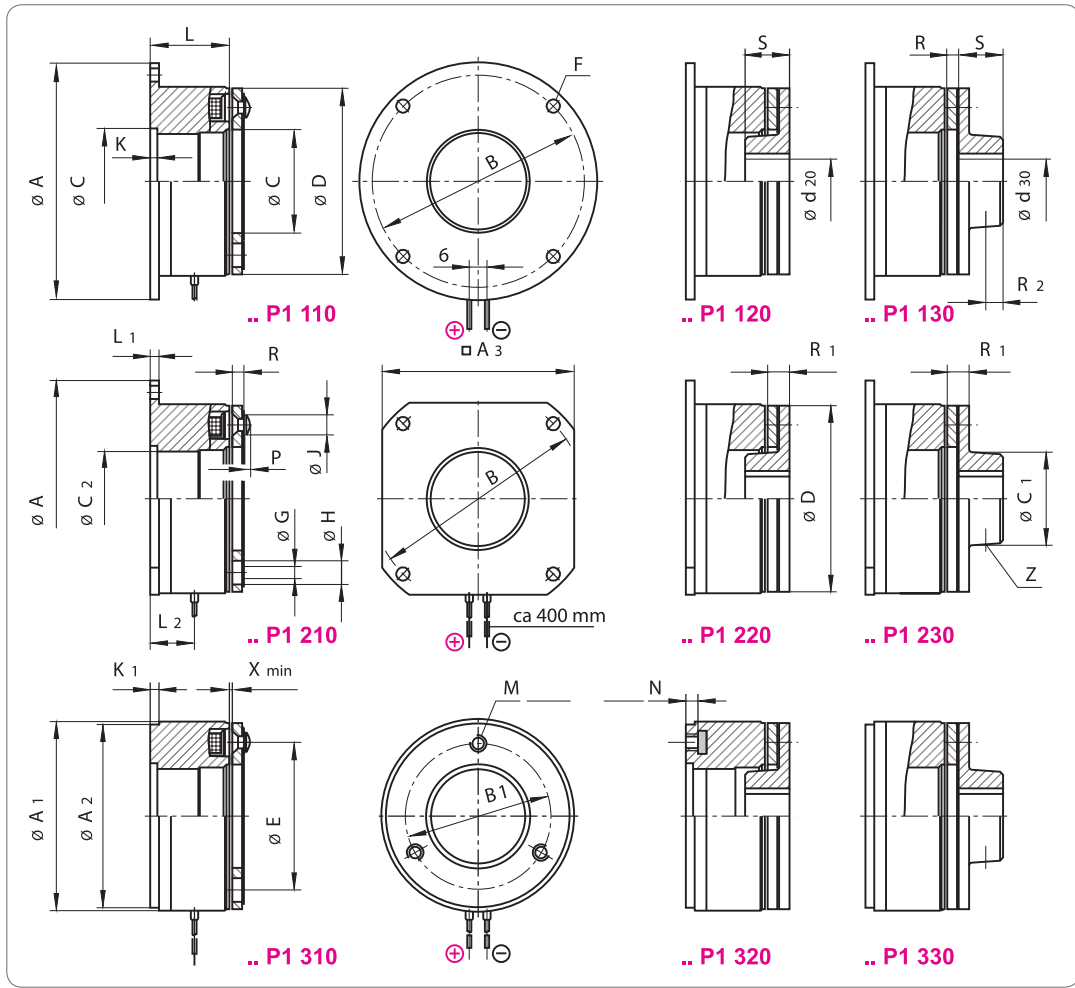

Size	M _{2N} ¹⁾ [Nm]	P ₂₀ [W]	A _{h8}	A ₁	A _{2h8}	A ₃	B	B ₁	C ^{H8}	C ₁	C ₂	D	E	ØF	G	H	J	K
01	0.4	8	39	28	28	32	33.5	22	11	13.5	-	28	19.5	3.4	2x2.1	5.3	4.5	-
02	1	10	45	32.2	32	34	38	23	12.5	16	-	32	23	3.4	3x2.6	6	5	-
03	2	11	54	41	40	42	47	28.5	19	22	-	40	30	3.4	3x3.1	6	5.5	-
05	4.5	12	65	51.5	50	53	58	40	26	24	24	50	38	3.4	3x3.1	6.5	5.5	2
06	9	18	80	64	63	66	72	49	35	32	32	63	50	4.5	3x4.1	10	8	2
07	18	24	100	80.8	80	83	90	63	42	38	38	80	60	5.5	3x4.1	11	8	2
08	36	26	125	101	100	103	112	78	52	48	48.5	100	76	6.5	3x5.1	11.5	10	2.5
09	72	40	150	126	125	128	137	106	62	57	58	125	95	6.5	3x6.1	15	11.5	3.5
10	145	50	190	161	160	163	175	135	80	71	75	160	120	9	3x8.1	21	14.5	3.5

Size	K ₁	L	L ₁	L ₂	M	N	P	R	R ₁	R ₂	S	d ₂₀ ^{H7}	d ₃₀ ^{H7}	d ₃₀ ^{H7}	X _{min}	X _{max} ^{20°}	Z	Weight kg
01	3	19.5	2	10.5	2xM3	3	1	2.25	4.25	2.7	7	6	6	8	0.15	0.3	1xM3	0.1
02	2	21.5	2	10.5	3xM3	3	1.3	2.1	4.1	4	10	8	8	10	0.15	0.3	1xM3	0.1
03	2	22.5	2	12	3xM3	3	1.5	2.6	5.2	5	12	10	12	15	0.15	0.4	1xM4	0.2
05	2	28.5	2	14	3xM3	3	1.5	3	6	5	12	15	15	19	0.2	0.5	1xM5	0.35
06	3	26.8	3	15	3xM4	4	2	3.9	7.4	6	15	18	18	25	0.3	0.65	1xM6	0.55
07	3	29.9	3	16.5	3xM4	5	2	4.5	8.5	8	20	25	25	30	0.3	0.8	1xM6	0.85
08	4	33.9	4	19.5	3xM5	6.2	2.5	6.2	11.2	10	25	30	30	38	0.35	0.9	1xM8	1.6
09	5	37.8	5	23	3xM6	7	3	7.3	13.3	12	30	40	40	50	0.4	1.0	2xM10	2.9
10	6	42.6	6	24	3xM8	9.5	4	9.4	16.4	15	38	50	50	65	0.5	1.2	2xM10	5.4

All dimensions in mm keyway to DIN 6885/1-P9 standard voltage 24 V DC (release range + 6% / - 10%) according to VDE 0580, isolation class "F" hub DIN 6885/1 ¹⁾ rated torque after running in process

COMBIPERM PC are permanent magnet **clutches**, which transmit in currentless condition frictionally engaged torque. The magnetic circle is optimized by the arrangement of the permanent magnets in the armature, thus permitting the transmission of high torques on small constructional spaces. The opening of the friction-type connection takes place by the antipole connection of the electromagnetic circuit, thereby neutralizing the force action of the permanent magnets

Range of application: e.g. robot technique, medical equipment

Size	M _{ZN} ¹⁾ [Nm]	P ₂₀ [W]	Data
06	6	18	upon request
07	12	24	
08	24	28	
09	50	35	
10	120	50	

¹⁾ rated torque after running in process



07PC230-xxxx

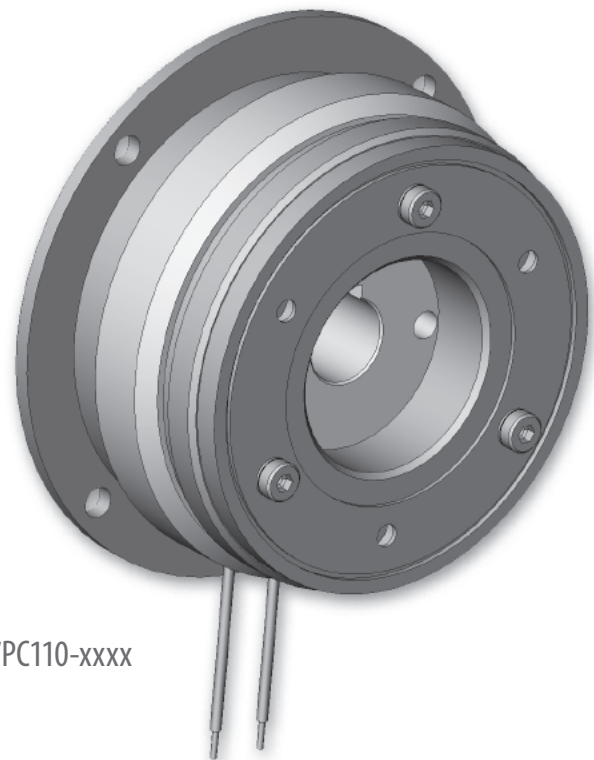

07PC110-xxxx

Permissible friction W_{Rmax} [J]
depending on the switching frequency type P1

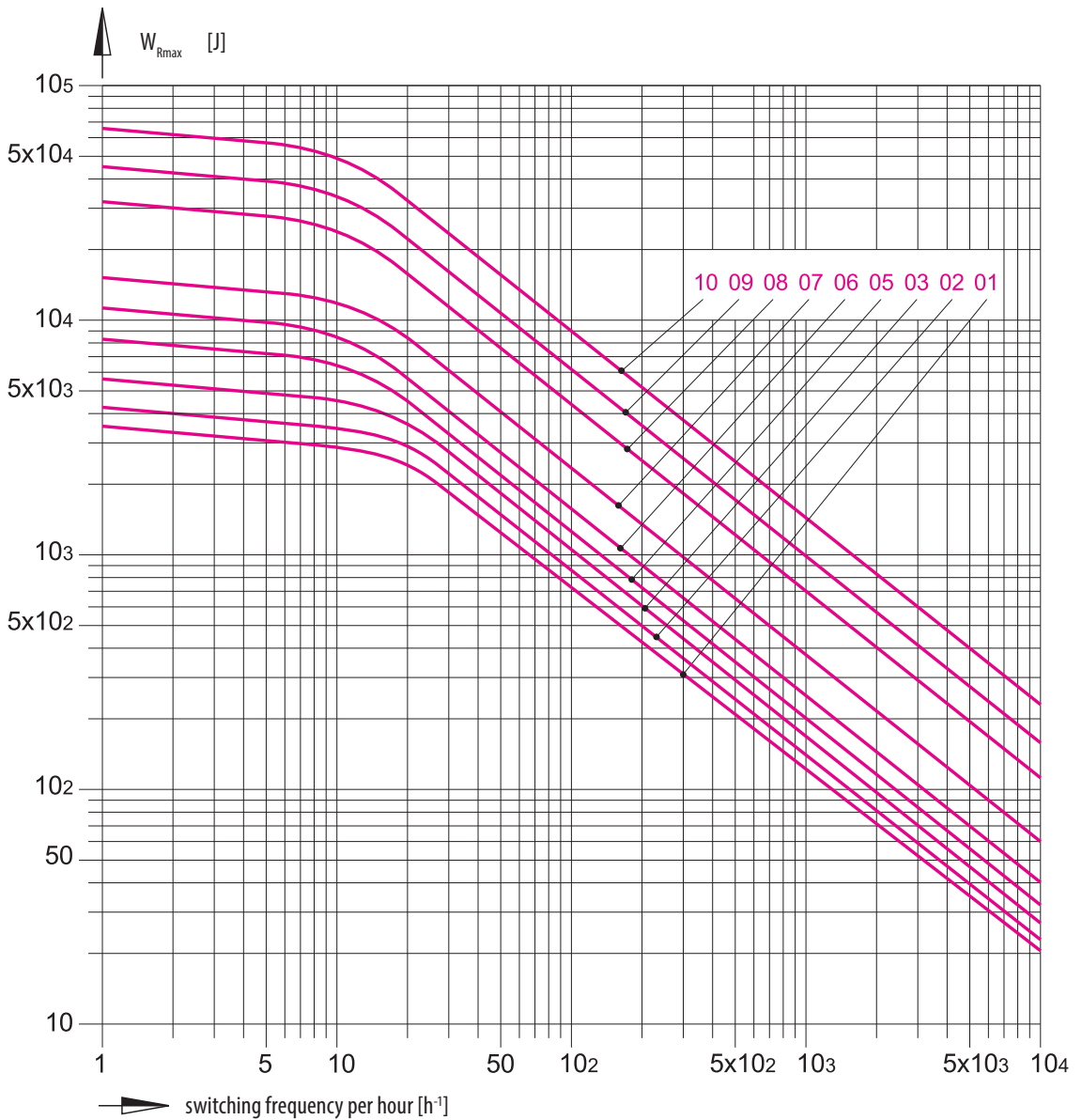

The values for W_{Rmax} apply to a speed 3000 rpm. Dependent on the actual application W_{Rmax} may exceed or fall below these values.

Power Supply

COMBIPERM P1 needs a smoothed DC voltage. To ensure a safe operation in case of large temperature variations, the coil should be supplied with constant current.

Please pay attention to the polarity of the connection leads.
(positive = red, negative = black).

COMBIPERM P1			01	02	03	05	06	07	08	09	10
Size											
M_{2N}	20 °C	[Nm]	0.4	1	2	4.5	9	18	36	72	145
$M_{stat.}$	100 °C		0.35	0.8	1.8	4	8	15	32	62	130
$M_{dyn.}$	20 °C	[Nm]	0.3	0.8	1.7	3.8	7.5	15	28	55	110
		[kgm ²]	0.001	0.001	0.001	0.001	0.002	0.004	0.012	0.036	0.1
		[rpm]	3,000	3,000	3,000	3,000	2,000	2,000	2,000	2,000	2,000
P_{20}		[W]	8	10	11	12	18	24	26	40	50
J											
Armature	P1.110		0.01	0.014	0.045	0.122	0.37	1.15	4	11.5	39
	P1.120/130		0.013	0.021	0.068	0.18	0.54	1.66	5.56	16	53
$W_{R0,1}$		[kJ]	200	300	410	580	890	1290	2900	6200	13000
		[kgm ²]	0.001	0.001	0.001	0.001	0.0015	0.004	0.0120	0.036	0.1
		[rpm]	3,000	3,000	3,000	3,000	2,000	2,000	2,000	2,000	2,000
X_{max}	20 °C	[mm]	0.3	0.3	0.4	0.5	0.65	0.8	0.9	1	1.2
X_{min}			0.15	0.15	0.15	0.2	0.3	0.3	0.35	0.4	0.5
n_{max}		[rpm]	10,000	10,000	10,000	10,000	10,000	10,000	10,000	8,000	8,000
Switching times	t_2	[ms]	10	12	25	35	40	50	90	140	190
	$t_{11} =$		2	2	2	2	2	3	3	7	12
	$t_1 =$		6	6	6	7	7	10	22	25	65

Legend					
M_{2N}	rated torque after running in process (slip speed 20 rpm)	[Nm]	t_1	Engaging time: Time from disconnecting the current until the rated torque is attained.	[ms]
$M_{stat.}$	rated torque at 100 °C (slip speed 20 rpm)	[Nm]	t_{11}	Engaging delay time: Time from disconnecting the current until the torque rises.	[ms]
$M_{dyn.}$	switching torque at specified conditions	[Nm]	t_2	Release time: Time from connecting the current until the torque decreases.	[ms]
P_{20}	power at 20 °C	[W]			
J	moment of inertia	[kgm ²]			
n_{max}	max. speed	[min ⁻¹]			
X_{min}	nominal air gap	[mm]			
X_{max}	max. air gap at which the armature attracts	[mm]			
$W_{R0,1}$	friction work up to 0.1 mm abrasion	[kJ]			

The stated switching times are achieved with adjusted nominal air-gap (x_{min}). These are averages whose dispersion depends on the power supply and coil temperature.

COMBINORM - operating-current operated brakes and clutches use the flux of an electromagnet, concentrated on two pole surfaces, for the connecting, separating or holding of shafts and the connected loads.

COMBINORM covers a complete program with brakes, clutches and combinations as installation and attachment components for the applications in machines, plants and equipment in the application range of 0.5 to 500 Nm.

On request we adapt the **KEB COMBINORM** to your constructional and electrical requirements. Please bear in mind that the rated torques are achieved after a required running-in process.

Program Schedule

COMBINORM Operating-current operated brakes and clutches			
Operating current brake	0.5 ... 500 Nm	page 24	COMBINORM B
Operating current clutch-brake-combination	7 ... 500 Nm	page 26	COMBINORM K
Operating current clutch	0.5 ... 500 Nm	page 26	COMBINORM C
Operating current toothed clutch	21 ... 390 Nm	page 32	COMBINORM T

Technical Data

Switching times	page 34
Moments of inertia, friction, rating	page 35
Dimensioning / Calculations	page 50
Bores table COMBINORM / COMBIPERM	page 51

Ordering example: COMBINORM C

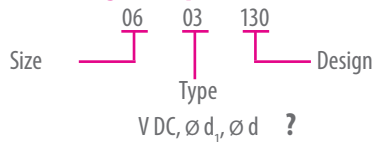

Installation Examples

flange mounted brakes

COMBINORM B .. 02120...

- ① brake magnet
- ② armature
- ⑤ hub
- ⑥ spring

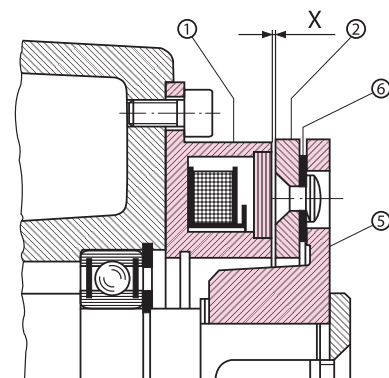

flange mounted clutches

COMBINORM C and T .. 03110...

- ② armature
- ③ clutch magnet
- ④ rotor
- ⑥ spring

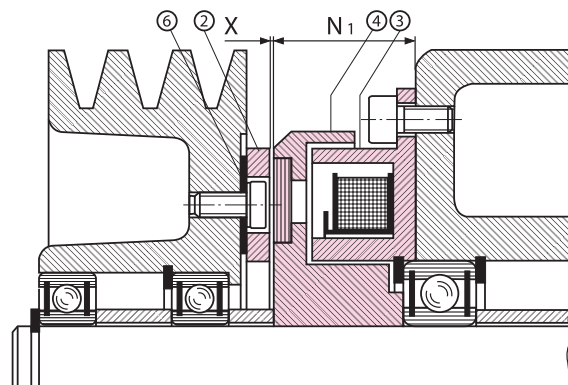

shaft mounted clutches

COMBINORM C and T .. 03810...

- ② armature
- ③ clutch magnet
- ④ rotor
- ⑥ spring

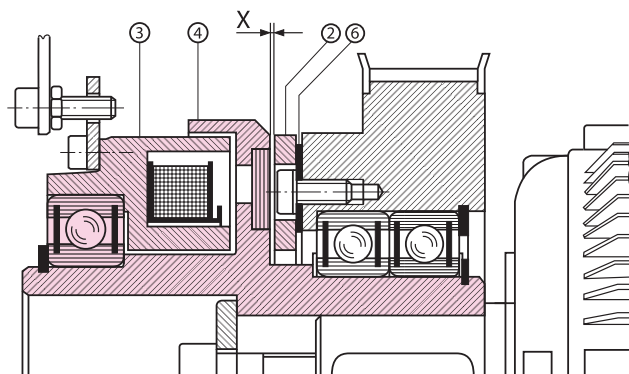

clutch-brake-combination

COMBINORM K .. 04170...

- ① brake magnet
- ② armature
- ③ clutch magnet
- ④ rotor
- ⑤ hub
- ⑥ spring

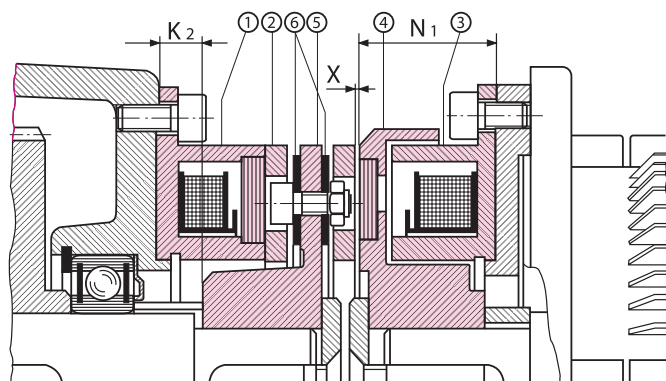

COMBINORM B are the most economical solution for the deceleration and holding of loads for the flange- and shaft-mounted installation in machines and plants. The magnets with a rated voltage of 24 V DC are designed according to ISO class B and are available in various special voltages on request.

COMBINORM

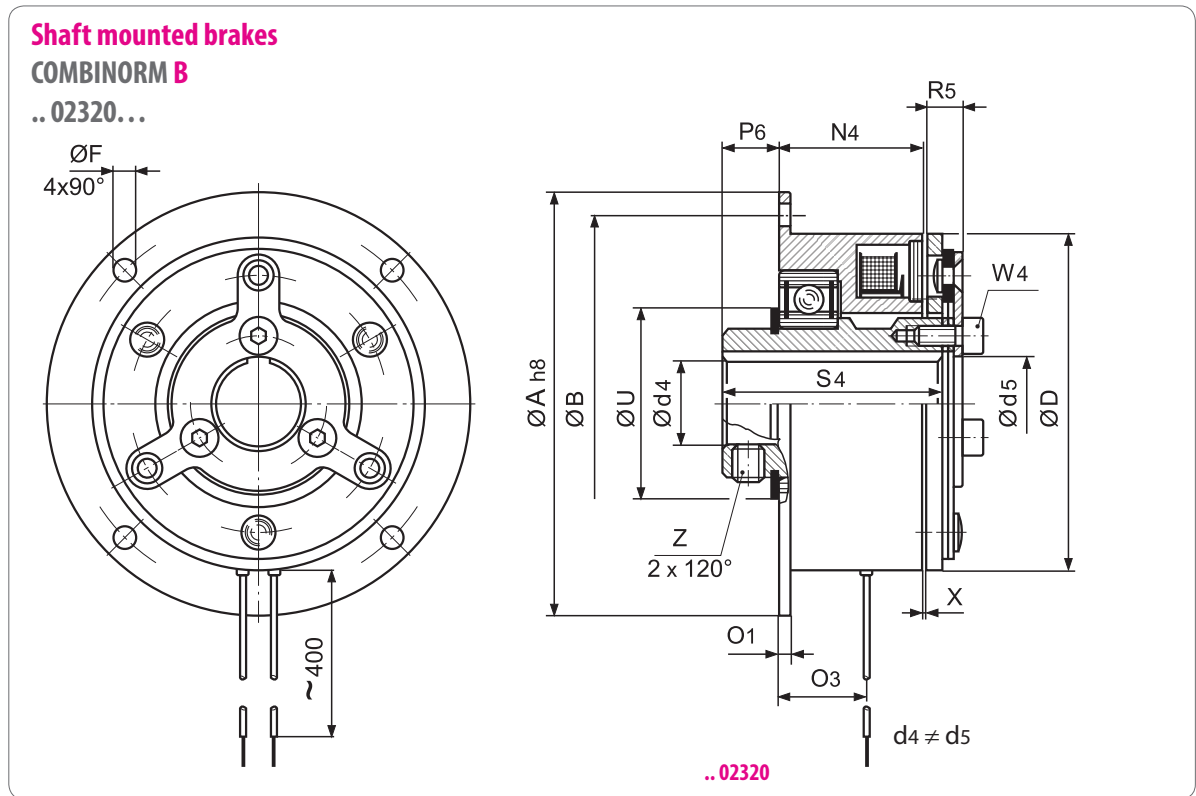

available shaft diameters page 51

Size	$M_{2N}^{(1)}$ [Nm]	P_{20} [W]	A_{h8}	B	C^{H8}	C_1	C_2	d/d ₄ max	d ₅	D	E	F	G	H	J	K	K ₁
01	0.5	6	39	33.5	11	13.5	-	6		28	19.5	3.4	2 x 2.1	5.3	4.5	-	-
02	0.75	6	45	38	13	16	13.6	8		32	23	3.4	3 x 2.6	6	5	3	1.1
03	1.5	8	54	47	19	22	20	10		40	30	3.4	3 x 3.1	6	5.5	3	1.1
05	3	10	65	58	26	24	27	15		50	38	3.4	3 x 3.1	6.5	5.5	3.2	1.3
06	7	12	80	72	35	32	36	20	18	63	50	4.5	3 x 4.1	10	8	3.5	1.6
07	15	16	100	90	42	38	43.5	22	21	80	60	5.5	3 x 4.1	11	8	4.25	1.85
08	30	21	125	112	52	48	53.8	30	28	100	76	6.6	3 x 5.1	11.5	10	5	2.15
09	65	28	150	137	62	58	63.8	35	35	125	95	6.6	3 x 6.1	15	11.5	5.5	2.15
10	130	38	190	175	80	73	82.1	45	44	160	120	9	3 x 8.1	21	14.5	6	2.65
11	250	50	230	215	100	92	102.1	60		200	158	9	3 x 10.1	19	17.5	7	3.15
12	500	65	290	270	125	112	127.4	70		250	210	11	4 x 12.1	28	20.5	8	4.15
13	Dimensions and technical data see drawing 02.004-4-01001																

All dimensions in mm Ø „d“ keyway according to DIN 6885/1-P9 (design ..02110/120/130) Ø „d4“ keyway according to DIN 6885/1-H8 (design ..02230)

COMBINORM K covers a series of houseless construction units, designed for the connection and holding of auxiliary drives, allowing a backlash-free transmission with spring-controlled armature systems.

The installation is done directly in the machine construction.

Range of application: e.g. paper processing, laundry folding equipment, feeder

available shaft diameters page 51

Size	M _{2N} ¹⁾ [Nm]	P ₂₀ [W]	A _{h8}	B	C ^{H8}	C ₂ max.	d max.	d ₁	F	K	K ₁	K ₂	L ₅	N	N ₁	O	O ₁	R ₂	S	S ₆	X	Weight [kg]
06	7	15	12	80	72	35	36	20	20	4.5	3.5	1.6	11.2	18	24	6	3	12.9	15	20	0.2	0.85
07	15	20	16	100	90	42	43.5	22	25	5.5	4.25	1.85	9.3	20	26.5	7	3	14.6	20	22	0.2	1.5
08	30	28	21	125	112	52	53.8	30	30	6.6	5	2.15	8.9	22	30	8	4	18.8	25	24.5	0.2	2.7
09	65	35	28	150	137	62	63.8	35	35	6.6	5.5	2.15	7.9	24	33.5	9	4	21.8	30	27.5	0.3	4.8
10	130	50	38	190	175	80	82.1	45	50	9	6	2.65	5	26	37.5	11	5	27	38	31	0.3	9.5
11	250	68	50	230	215	100	102.1	60	65	9	7	3.15	3.4	30	44	12	5	33.8	48	37	0.4	17.9
12	500	85	65	290	270	125	127.4	70	80	11	8	4.15	5.1	35	51	15	6	39.2	55	43.5	0.4	31.5

All dimensions in mm keyway according to DIN 6885/1-P9 Standard voltage 24 V DC VDE 0580, ISO-class „B“ ¹⁾ rated torque after running in process

COMBINORM C the switchable shaft connections are proven millions of times in the machine building and allow the controlled connection and disconnection of functional parts in an especially easy manner.

Electromagnets according to ISO class B with rated voltage of 24 V DC create a flux, whose effect leads over the pole surfaces of the rotors and armatures.

Available on request in various special voltages.

Range of application: z. B. e.g. paper processing, winding drives, door and gate systems, feed strapping machines, sorting machines

available shaft diameters page 51

Size	M _{2N} ¹⁾ [Nm]	P ₂₀ [W]	A _{h8}	B	C ^{H8}	C ₁	C ₂	d max	d ₁ max	D	E	F	G	H	J	K
01	0.5	6	39	33.5	11	13.5	-	6	6	28	19.5	3.4	2 x 2.1	5.3	4.5	-
02	0.75	6	45	38	13	16	13.6	8	8	32	23	3.4	3 x 2.6	6	5	3
03	1.5	8	54	47	19	22	20	10	10	40	30	3.4	3 x 3.1	6	5.5	3
05	3	10	65	58	26	24	27	15	15	50	38	3.4	3 x 3.1	6.5	5.5	3.2
06	7	15	80	72	35	32	36	18	20	63	50	4.5	3 x 4.1	10	8	3.5
07	15	20	100	90	42	38	43.5	22	25	80	60	5.5	3 x 4.1	11	8	4.25
08	30	28	125	112	52	48	53.8	30	30	100	76	6.6	3 x 5.1	11.5	10	5
09	65	35	150	137	62	58	63.8	35	35	125	95	6.6	3 x 6.1	15	11.5	5.5
10	130	50	190	175	80	73	82.1	45	50	160	120	9	3 x 8.1	21	14.5	6
11	250	68	230	215	100	92	102.1	60	65	200	158	9	3 x 10.1	19	17.5	7
12	500	85	290	270	125	112	127.4	70	80	250	210	11	4 x 12.1	28	20.5	8

All dimensions in mm keyway according to DIN 6885/1-P9 Standard voltage 24 V DC VDE 0580, ISO-class „B“ ¹⁾ rated torque after running in process

COMBINORM

Clutch-brake-combination

COMBINORM K

.. 04170...

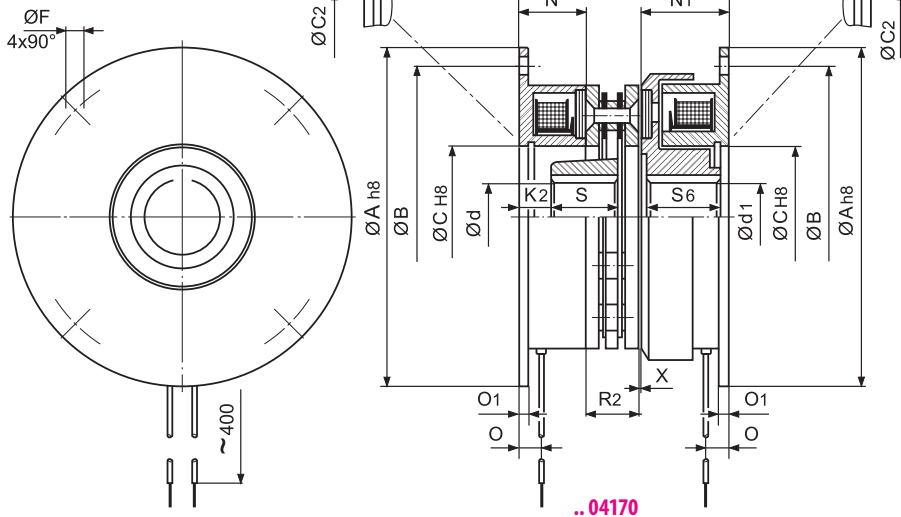

Flange mounted clutches

COMBINORM C

.. 031X0...

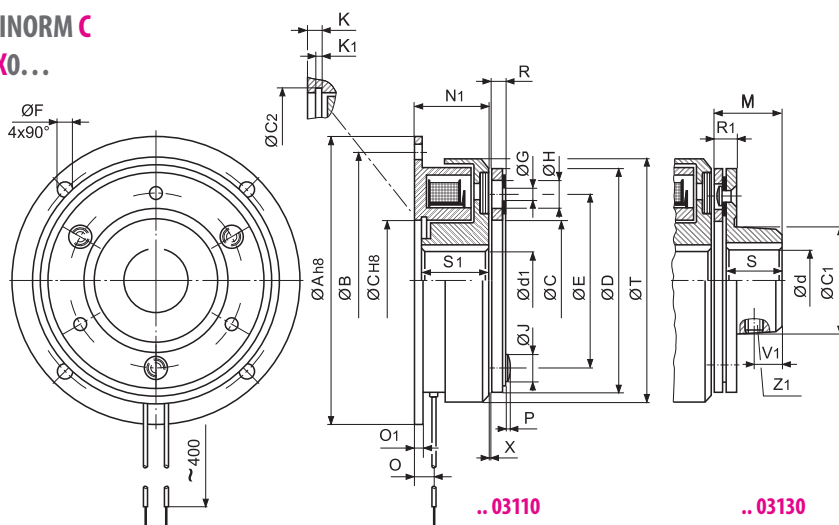

K ₁	M	N ₁	O	O ₁	P	R	R ₁	S	S ₁	T	V ₁	X	Z ₁	Weight [kg]	
														110	130
-	9.3	18	5	1.5	1	2.3	4.3	7	16.5	31	2.5	0.1	1 x M3	0.1	0.1
1.1	12.1	22.2	7.5	2	1.3	2.1	4.1	10	20.2	34	4	0.15	1 x M3	0.1	0.1
1.1	14.7	25.4	7	2	1.5	2.7	5.3	12	23.4	43	5	0.15	1 x M4	0.2	0.2
1.3	15	28.1	7.5	2	1.5	3	6	12	26.1	54	5	0.2	1 x M5	0.35	0.4
1.6	18.8	24	6	3	2	3.8	7.3	15	22	67	6	0.2	1 x M6	0.5	0.5
1.85	24.3	26.5	7	3	2	4.3	8.3	20	24	85	8	0.2	1 x M6	0.9	1
2.15	31	30	8	4	2.5	6	11	25	27	106	10	0.2	1 x M8	1.6	1.8
2.15	36.9	33.5	9	4	3	6.9	12.9	30	30	133	12	0.3	2 x M10	2.8	3.1
2.65	46.9	37.5	11	5	4	8.9	15.9	38	34	169	15	0.3	2 x M10	5.6	6.3
3.15	59.2	44	12	5	4.5	11.2	20.2	48	40	212.5	19	0.4	2 x M12	9.7	11
4.15	68	51	15	6	5	13	24	55	47	266	22	0.4	2 x M12	17.9	20.3

Shaft mounted clutches size 01 ... 07

COMBINORM C

.. 036X0...

table (1)

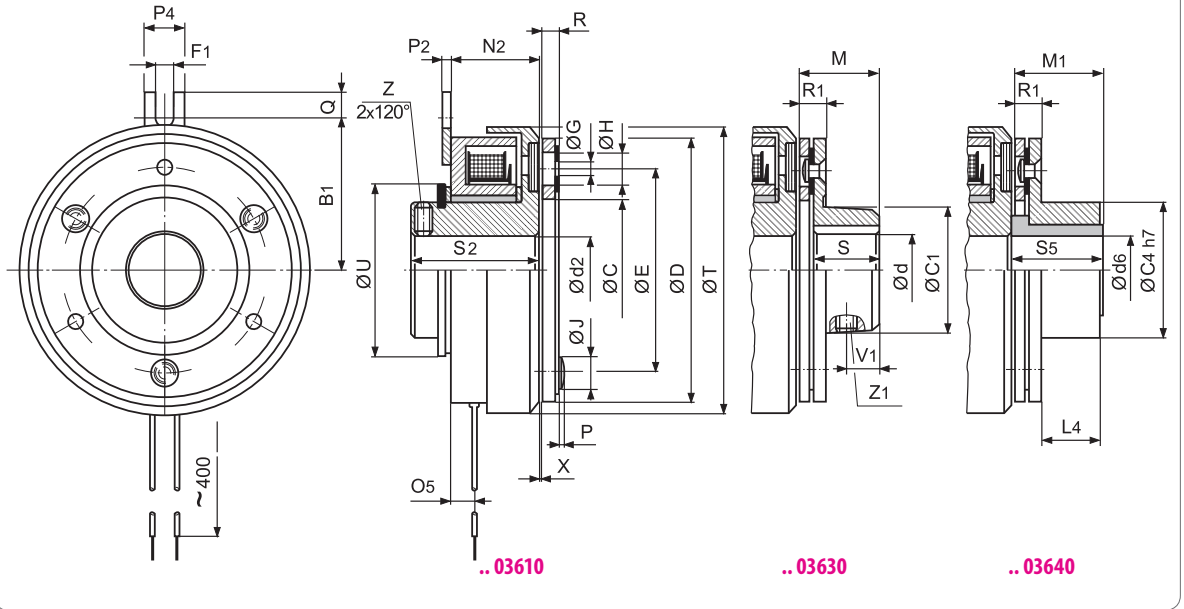

available shaft diameters page 51

table (1)

Size	M _{2N} ¹⁾ [Nm]	P ₂₀ [W]	B ₁	C	C ₁	C ₄	d max	d ₂ max	d ₆ max	D	E	F ₁	G	H	J	L ₄	M	M ₂
01	0.5	6	16.8	11	13.5	13	6	6	6	28	19.5	3.1	2 x 2.1	5.3	4.5	4.8	9.3	9.3
02	0.75	6	20	13	16	14	8	6	6	32	23	3.1	3 x 2.6	6	5	7.8	12.1	12.1
03	1.5	8	23	19	22	18	10	10	10	40	30	3.1	3 x 3.1	6	5.5	9.1	14.7	14.7
05	3	10	28	26	24	28	15	17	15	50	38	3.1	3 x 3.1	6.5	5.5	8.8	15	15
06	7	15	36	35	32	-	18	20	-	63	50	5.2	3 x 4.1	10	8	-	18.8	-
07	15	20	45	42	38	-	22	25	-	80	60	5.2	3 x 4.1	11	8	-	24.3	-

table (2)

Size	M _{2N} ¹⁾ [Nm]	P ₂₀ [W]	A _{h8}	A ₁	B	B ₁	C	C ₁	d max	d ₃ max	D	D ₂	E	E ₁	F	F ₁	G	H	J
06	7	15	80	-	72	-	35	32	18	17	63	-	50	-	4.5	-	3 x 4.1	10	8
07	15	20	100	-	90	-	42	38	22	22	80	-	60	-	5.5	-	3 x 4.1	11	8
08	30	28	-	62.5	-	56	52	48	30	30	100	85	76	45.75	-	6.5	3 x 5.1	11.5	10
09	65	35	-	75	-	68.5	62	58	35	35	125	95	95	55	-	6.5	3 x 6.1	15	11.5
10	130	50	-	95	-	87.5	80	73	45	50	160	126	120	72.5	-	9	3 x 8.1	21	14.5
11	250	68	-	115	-	107.5	100	92	60	50	200	126	158	88	-	9	3 x 10.1	19	17.5
12	500	85	-	145	-	135	125	112	70	60	250	160	210	110	-	11	4 x 12.1	28	20.5

All dimensions in mm keyway according to DIN 6885/1-P9 Standard voltage 24 V DC VDE 0580, ISO-class „B“ ¹⁾ rated torque after running in process

Shaft mounted clutches size 06 ... 12

COMBINORM C

.. 03.XX0...

design torque support

size 08... 12

size 06 + 07

design flange

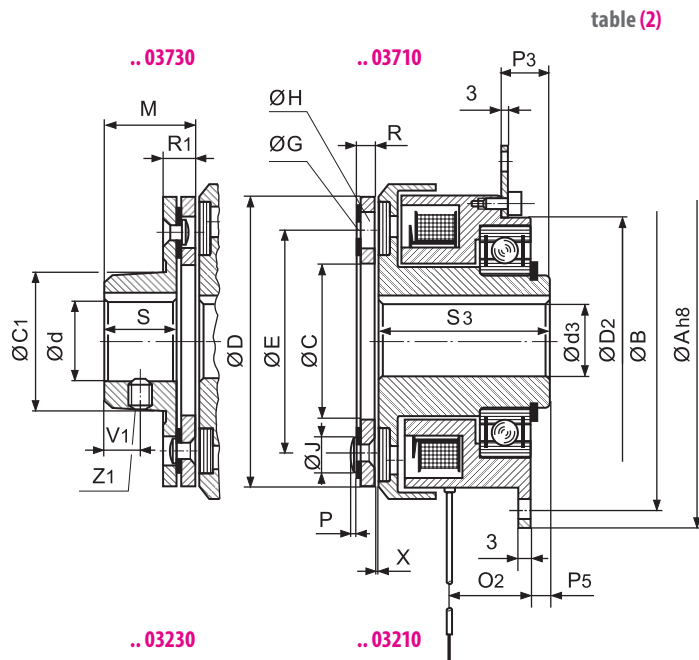
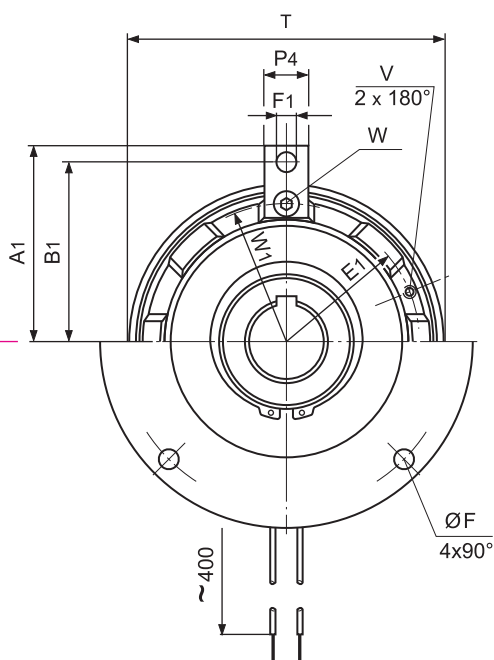

N ₂	O ₅	P	P ₂	P ₄	Q	R	R ₁	S	S ₂	S ₅	T	U	V ₁	X	Z	Z ₁	Weight [kg]	
																	110	130
17.3	3.6	1	1.5	8	3	2.3	4.3	7	23.5	9.4	31	17	2.5	0.1	M3	M3	0.1	0.1
19.8	5	1.3	1.5	8	3	2.1	4.1	10	26.2	12.25	34	21	4	0.15	M3	M3	0.1	0.1
23	5.1	1.5	1.5	8	3	2.7	5.3	12	30.4	14.85	43	23	5	0.15	M4	M4	0.2	0.2
26.1	7.8	1.5	1.5	8	3	3	6	12	34.1	15.2	54	32	5	0.2	M4	M5	0.35	0.4
24	6	2	2.5	12	7	3.8	7.3	15	33	-	67	41	6	0.2	M4	M6	0.5	0.5
26.5	7	2	2.5	12	7	4.3	8.3	20	38	-	85	50	8	0.2	M6	M6	0.9	1

M	O ₂	P	P ₃	P ₄	P ₅	R	R ₁	S	S ₃	T	V	V ₁	W	W ₁	X	Z ₁	Weight [kg]	
																	210/710	230/730
18.8	19	2	-	-	4	3.8	7.3	15	41	67	-	6	-	-	0.2	1xM6	0.8	0.9
24.3	21.5	2	-	-	4.5	4.3	8.3	20	45	85	-	8	-	-	0.2	1xM6	1.5	1.6
31	24	2.5	16.2	12	5.5	6	11	25	51.5	106	M5	10	M4	46.5	0.2	1xM8	2.3	2.5
36.9	25	3	18.7	14	5.5	6.9	12.9	30	55	133	M8	12	M5	55	0.3	2xM10	3.7	4.1
46.9	31.5	4	21.5	14	7	8.9	15.9	38	65	169	M8	15	M5	72.5	0.3	2xM10	7	7.7
59.15	32.5	4.5	23	20	7	11.15	20.15	48	71	212.5	M10	19	M6	88	0.4	2xM12	13.1	14.3
68	41	5	41	22	8	13	24	55	85	266	M10	22	M8	110	0.4	2xM12	23	25

Shaft mounted clutches with bearing take-up for the output
COMBINORM C
.. 03810...

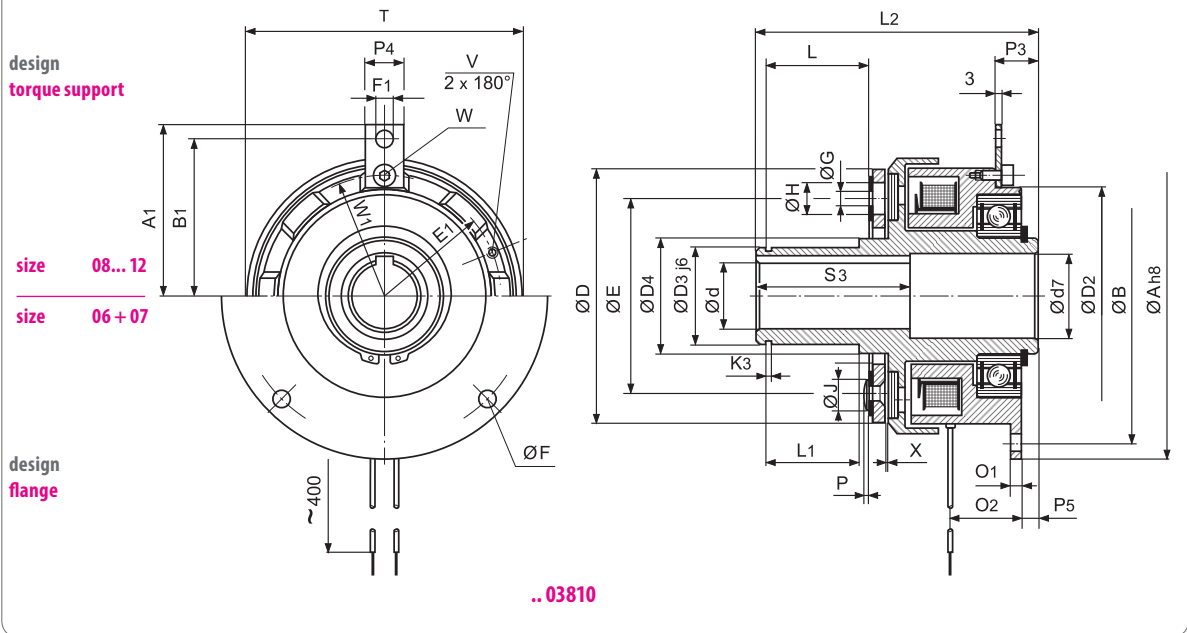

available shaft diameters page 51

Size	M _{2N} ¹⁾ [Nm]	P ₂₀ [W]	M _A ²⁾ [Nm]	A _{h8}	A ₁	B	B ₁	C ₅	D	D ₂	D ₃	D ₄	d ₄ max	d ₇ max	d	E	E ₁	E ₂	F	F ₁	G
06	7	15	10	80	-	72	-	30	63	-	25	29	19	17	16	50	-	44	4x4.5	-	3x4
07	15	20	25	100	-	90	-	40	80	-	35	40	26	25	22	60	-	68	4x5.5	-	3x4
08	30	28	25	-	62.5	-	56	45	100	85	40	46	30	28.5	25	76	45.75	80	-	6.5	3x5
09	65	35	50	-	75	-	68.5	60	125	95	50	57	38	33	35	95	55	100	-	6.5	3x6
10	130	50	140	-	95	-	87.5	85	160	126	70	76	55	41	50	120	72.5	140	-	9	3x8.1
11	250	68	220	-	115	-	107.5	100	200	126	70	76	65	48	50	158	88	165	-	9	3x10
12	500	85	500	-	145	-	135	125	250	160	80	89	85	52	60	210	110	215	-	11	4x12

All dimensions in mm keyway according to DIN 6885/1-P9 Standard voltage 24 V DC VDE 0580, ISO-class „B“ ¹⁾ rated torque after running in process ²⁾ tightening torque for W₂

For flexible **clutches** (type .. 03840) the following additional instructions are applicable:

The radial and axial screws connecting the rubber element to the hubs must all be tightened to the torque (M_A²⁾) given in the table, using a torque wrench.
 Ensure that when tightening the screws the aluminium bushes do not twist in the rubber part and that they sit squarely. In order to reduce friction between the screw head and the aluminium bush smear a small amount of grease under the head of the screw before fitting. If necessary use a suitable tool to apply counter pressure on the element to prevent twisting of the rubber part while tightening the screws. This is particularly important with the radial screws otherwise the curved faces between the aluminium bush and the hub will not engage on the full area but only across the two sides. This will inevitably lead to slackening of the screws and destruction of the clutch. If the clutch is supplied in a pre-assembled state, do not dismantle it, but fit it in this condition.

Shaft mounted clutches with flexible clutch

COMBINORM C

.. 03840...

design torque support

size 08... 12

size 06 + 07

design flange

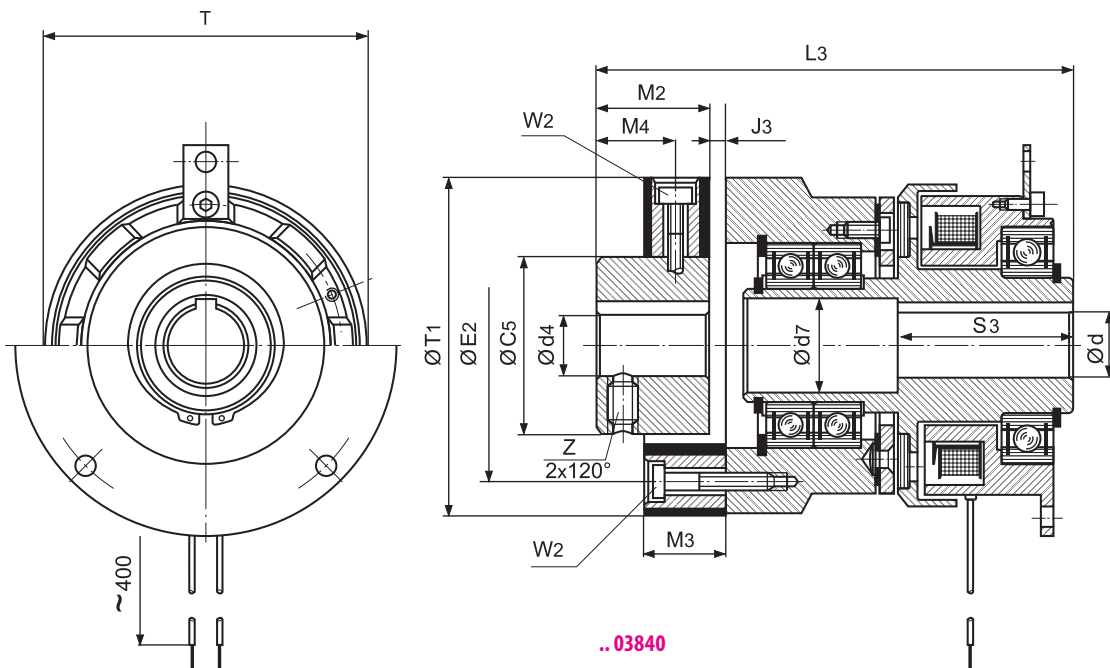

H	J	J ₃	K ₃	L	L ₁	L ₂	L ₃	M ₂	M ₃	M ₄	O ₁	O ₂	P	P ₃	P ₄	P ₅	S ₃	T	T ₁	V	W	W ₁	W ₂	X	Z	Weight [kg]	
																										810	840
10	8	2	1.3	32.9	25.6	80	117	30	24	19	3	19	2	-	-	4	41	67	56	-	-	-	2xM6	0.2	M5	1	1.7
11	8	4	1.6	37.7	29.9	90	129	30	24	20	3	21.5	2	-	-	4.5	45	85	85	-	-	-	2xM8	0.2	M6	1.8	3
11.5	10	4	1.85	35.2	32.15	96	141	35	28	23	-	24	2.5	16.2	12	5.5	51.5	106	100	M5	M4	46.5	3xM8	0.2	M8	2.7	4.1
15	11.5	4	2.15	37.6	34.6	103	160	45	32	31	-	25	3	18.7	14	5.5	55	133	120	M8	M5	55	3xM10	0.3	M10	4.2	7.4
21	14.5	6	2.65	47.8	43.1	126	200	60	46	40	-	31.5	4	21.5	14	7	65	169	170	M8	M5	72.5	3xM14	0.3	M10	8.3	14.6
19	17.5	8	2.65	47.5	43.3	134	217	65	58	40	-	32.5	4.5	23	20	7	82	212.5	200	M10	M6	88	3xM16	0.4	M12	14.5	24.4
28	20.5	8	2.65	59.6	55.3	162	260	80	70	49	-	41	5	27	22	8	85	266	260	M10	M8	110	3xM20	0.4	M12	26	45.2

Size	Compliance [mm] of flexible clutches	
	radial	axial
06	1.5	2
07	1.5	3
08	1.5	3
09	2	4
10	2	5
11	2	5
12	2	5



COMBINORM T are electromagnetically operated tooth clutches for wet or dry operation. Torque is transmitted by the leading faces of hardened serrations and is backlash free.

Large torques are transmitted with less space requirements in both directions.

On request available in various special voltages.

Range of application e.g. door drives
printing machines
transport roller
aggregate connection



COMBINORM

Flange mounted tooth clutches
COMBINORM T
..071X0...

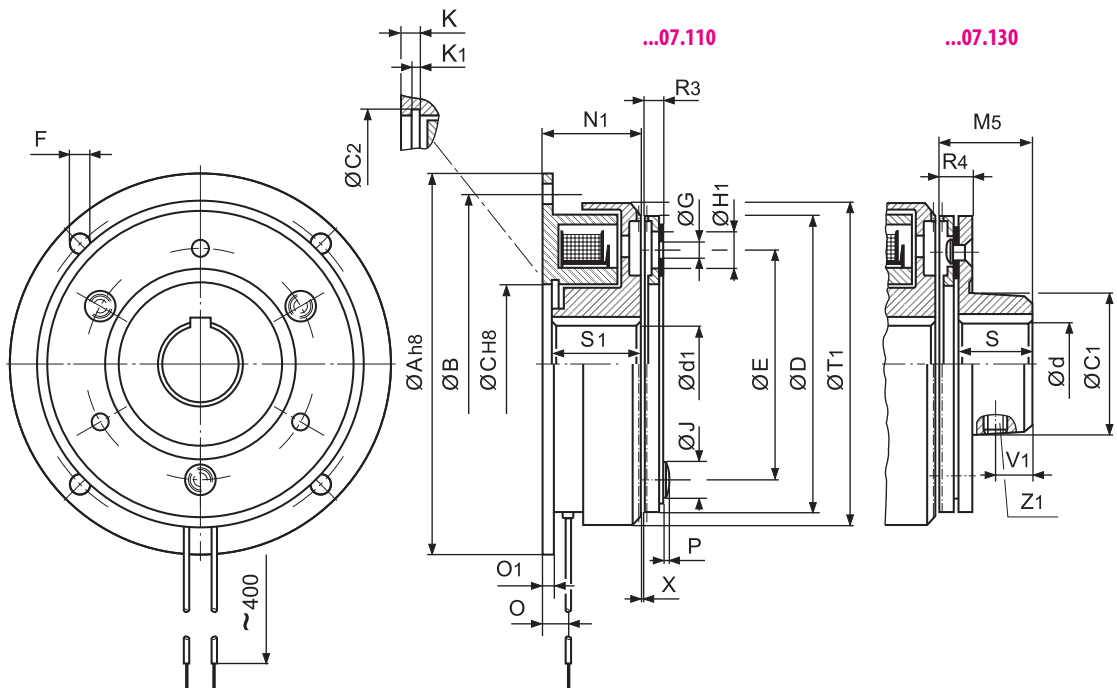

Shaft mounted tooth clutches

COMBINORM T

.. 07XX0...

design torque support

size 08... 10

size 06 + 07

design flange

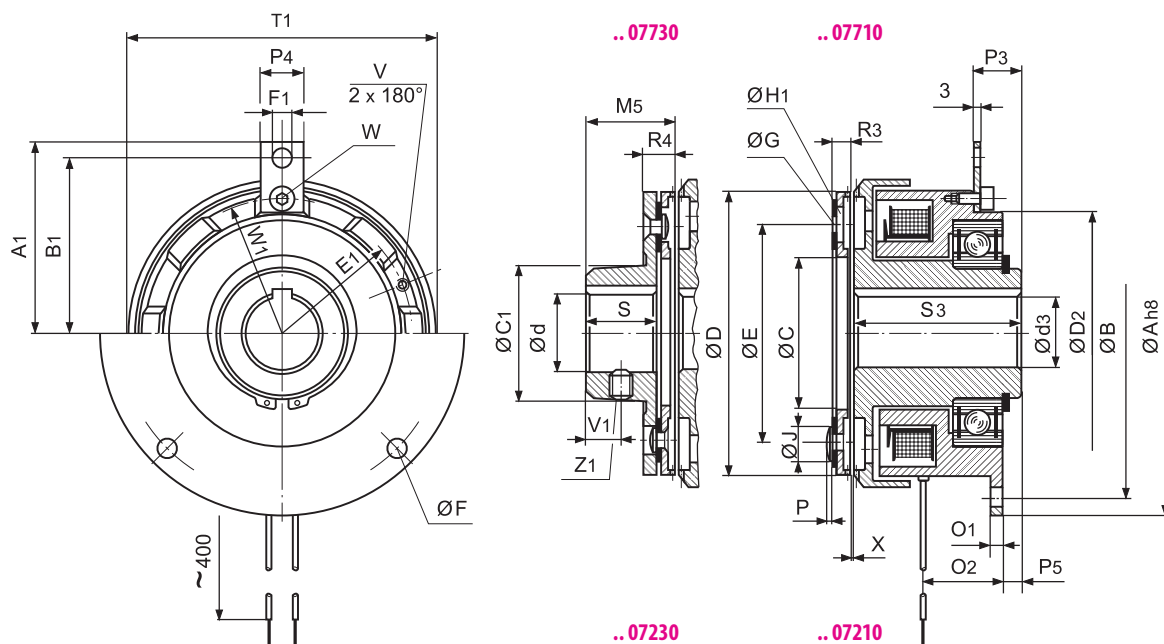

available shaft diameters page 51

Size	M _{2N} [Nm]	P ^{20°C} [W]	A _{h8}	A ₁	B	B ₁	C ^{H8}	C ₁	C ₂	D	d ₁ max	D ₂	d ₃ max	d max	E	E ₁
06	21	15	80	-	72	-	35	32	36	63	20	-	17	18	50	-
07	45	20	100	-	90	-	42	38	43,5	80	25	-	22	22	60	-
08	90	28	125	62,5	112	56	52	48	53,8	100	30	85	30	30	76	45,75
09	195	35	150	75	137	68,5	62	58	63,8	125	35	95	35	35	95	55
10	390	50	190	95	175	87,5	80	73	82,1	160	50	126	50	45	120	72,5

Size	F	F ₁	G	H ₁	J	K	K ₁	M ₅	N ₁	O	O ₁	O ₂	P	P ₃	P ₄	P ₅
06	4x4,5	-	3x4,1	8	8	3,5	1,6	20,3	24	6	3	19	2	-	-	4
07	4x5,5	-	3x4,1	8	8	4,25	1,85	26,4	26,5	7	3	21,5	2	-	-	4,5
08	4x6,6	6,5	3x5,1	11,2	10	5	2,15	33,6	30	8	4	24	2,5	16,2	12	5,5
09	4x6,6	6,5	3x6,1	15	11,5	5,5	2,15	41,2	33,5	9	4	25	3	18,7	14	5,5
10	4x9	9	3x8,1	16	14,5	6	2,65	50,8	37,5	11	5	31,5	4	21,5	14	7

Size	R ₃	R ₄	S	S ₁	S ₃	T ₁	V	V ₁	W	W ₁	X	Z ₁	Weight [kg]			
													210/710	230/730	110	130
06	5,3	8,8	15	22	41	68	-	6	-	-	0,15	1xM6	1	1	0,7	0,7
07	6,4	10,4	20	24	45	86,5	-	8	-	-	0,2	1xM6	1,7	1,8	1,1	1,2
08	8,6	13,6	25	27	51,5	108	M5	10	M4	46,5	0,2	1xM8	2,6	2,8	1,9	2,1
09	11,2	17,2	30	30	55	135	M8	12	M5	55	0,2	2xM10	4,1	4,4	3,2	3,5
10	12,8	19,8	38	34	65	172,2	M8	15	M5	72,5	0,25	2xM10	7,5	8,3	6,1	6,9

All dimensions in mm keyway according to DIN 6885/1-P9 Standard voltage 24V DC VDE 0580, ISO-class „B“

DC-side switching

Current / time and torque / time diagrams

The mentioned designations of switching times are according to DIN VDE 580.

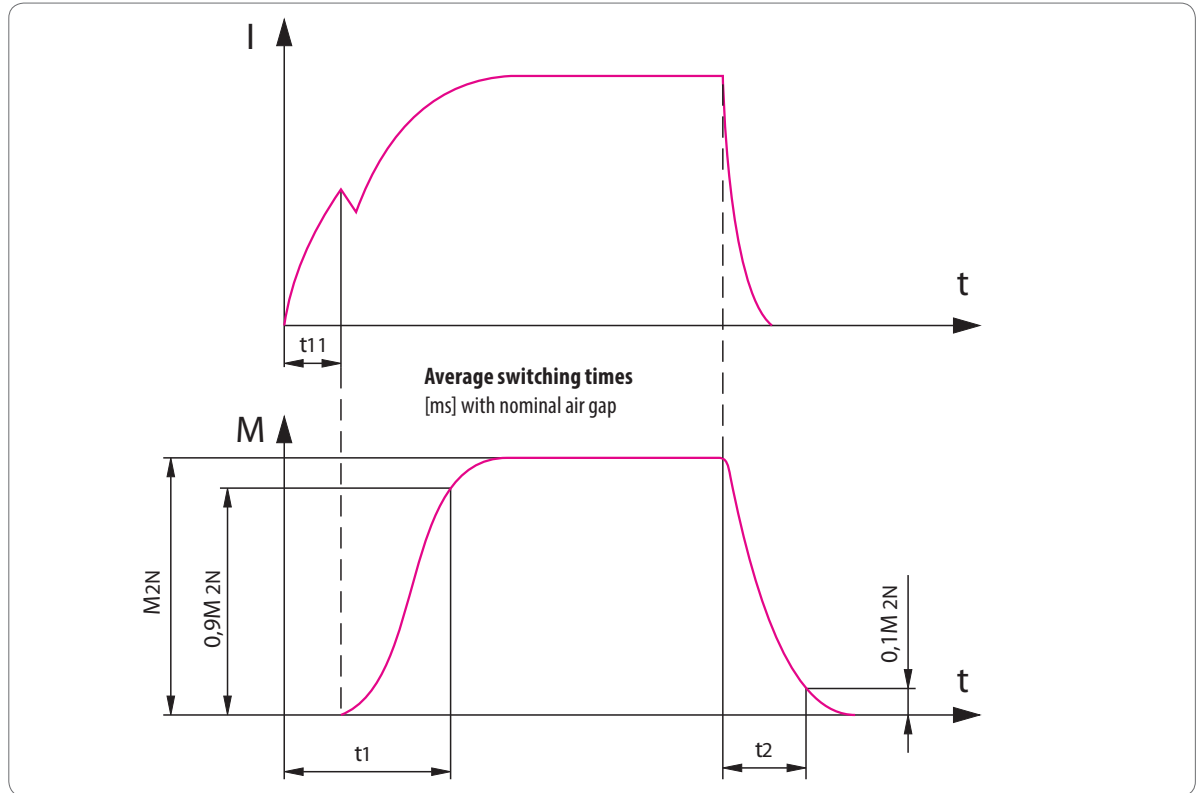

The specified switching times are achieved with adjusted nominal air gap (x_{min}). It concerns average values whose scattering depends on the current supply and the coil temperature.

The torques specified in the measuring tables are safely achieved with single-side clutches and brakes after a run-in phase at 100 rpm. In new condition and in case of substantially higher speeds the torques are possibly smaller.

Current supply

The **COMBINORM** requires a DC voltage, which can be made available by different rectifiers, transformer rectifiers as well as electronic switches of the series **COMBITRON 91** and **94**.

A short-time overvoltage produces very short switching times and high switching accuracies.

Combinorm 02 / 03 / 04 / 07				01	02	03	05	06	07	08	09	10	11	12
Size														
M_{2N}	02/03/04 07	20 °C	[Nm]	0.5	0.75	1.5	3	7	15	30	65	130	250	500
								21	45	90	195	390		
P₂₀	02/04 brake 03/04/07 clutch	20 °C 20 °C	[W]	6	6	8	10	12	16	21	28	38	50	65
				6	6	8	10	15	20	28	35	50	68	85
J														
Armature	110/210/610/710/810 120/130/230/630/730 320 170		[10 ⁻⁴ kgm ²]	0.010 0.013	0.014 0.021	0.045 0.068	0.122 0.18	0.366 0.53	1.07 1.57	3.72 5.29	10.6 15.1	40 50.1	115 159	311 437
Rotor	110/130/140/170/610 630/640 210/230/240/710/730/740 810			0.025 0.027	0.035 0.038	0.15 0.17	0.375 0.4	0.825 0.9	2.38 2.6	7.25 8	21.9 24	67.4 73	200 220	450 500
								1.02	3.05	8.76	26	82.5	230	520
W_{Rmax.}	02/03/04		[10 ⁴ J]	0.04	0.05	0.08	0.12	0.19	0.31	0.48	0.75	1.25	2	2.9
W_{RO,1mm}	02/03/04		[10 ⁷ J]	0.23	0.3	0.43	0.63	0.95	1.63	2.53	4.09	6.66	10.4	16.3
P_{Rmax.}	02/04 brake 03/04 clutch		[J/s]	12.8 20.3	18.6 28.6	26.9 40.6	38.9 58.3	58.3 80.6	79.2 114	114 161	164 228	236 322	339 458	489 647
Xn_{max.} 20°	02/03/04 07		[mm]	0.3	0.45	0.45	0.6	0.7	0.7	0.7	0.9	1.0	1.2	1.2
X	02/03/04			0.1	0.15	0.15	0.2	0.2	0.2	0.2	0.3	0.3	0.4	0.4
n_{max.}	02/03/04/07 exception clutch! 03.610/630/640		[rpm]	10,000 1,500	10,000 1,500	10,000 1,500	10,000 1,500	8,000 1,500	6,000 1,500	5,000	4,000	3,000	3,000	2,000
Switching times														
Brake 02/04		t ₂ DC	[ms]	3	4	5	8	10	15	50	85	100	140	200
		t ₂ AC		17	20	25	40	70	95	240	300	400	600	800
	nominal voltage	t ₁₁ =		2	3	3	5	6	8	10	13	15	23	35
		t ₁ =		5	8	8	17	24	38	42	48	85	118	155
	3 x nominal voltage	t ₁₁ =		1	2	2	3	3	4	5	6	8	10	16
		t ₁ =		3	4	4	8	11	17	20	22	38	50	76
Clutch 03/04		t ₂ DC	[ms]	5	6	7	10	14	19	40	68	100	130	200
		t ₂ AC		17	19	22	30	39	61	115	220	400	650	900
	nominal voltage	t ₁₁ =		4	5	7	10	14	18	23	25	29	37	55
		t ₁ =		10	14	17	32	48	74	81	90	161	201	295
	3 x nominal voltage	t ₁₁ =		2	2	3	5	6	8	10	12	14	16	25
		t ₁ =		5	6	7	16	22	33	37	42	69	91	125

Legend

M _{2N}	rated torque after running in process	[Nm]	t	time	[ms]
M _{erf}	required torque	[Nm]	t ₁	Engaging time Time from connecting the current the rated torque is attained	[ms]
J	moment of inertia	[10 ⁻⁴ kgm ²]	t ₁₁	Engaging delay time: Time from connecting the current until the torque rises	[ms]
P ₂₀	power at 20 °C	[W]	t ₂	Release time: Time from disconnecting the current until 0.1 M _{2N}	[ms]
n _{max}	maximum speed	[min ⁻¹]			
X	rated air gap	[mm]			
X _n	clearance at which an adjustment is recommended	[mm]			
W _{Rmax}	permissible friction per switching operation	[10 ⁴ J]			
W _{RO,1}	friction work up to 0,1 mm wear	[10 ⁷ J]			
P _{Rmax}	permissible friction work per second	[J/s]			
I	magnet-rated current	[A]			

COMBIBOX Clutch-brake-combination type 10 / 09 / 06

with an energised to engage single sided clutch / brake COMBIBOX **10** page 37

with an energised to engage single sided clutch without brake COMBIBOX **09** page 37

with an energised to engage single sides clutch / and energised to disengage single sided permanent magnet brake COMBIBOX **06** page 37

Technical Data

COMBIBOX shaft in / shaft out page 38

COMBIBOX bore in / bore out page 39

COMBIBOX bore in / shaft out page 40

COMBIBOX shaft in / bore out page 41

Moment of inertia, friction work and calculations page 42

On request we adapt the COMBIBOX to your constructional and electrical requirements.

Design

Attachments

	input				
		360 / 370	380 / 390	460 / 470	440
output					
		570 / 580	410 / 430	450 / 480	670
		490	500	510	520
		530 / 540	550 / 560	590 / 600	610
		620 / 630	640 / 660	680 / 690	700
		800			

COMBIBOX

The **COMBIBOX** is a ready to install electromagnetic actuated clutch-brake module in a single housing.

The modular system is designed for a multitude of variants; these covering most of the applications in the field.

The patented adjustment procedure permits an air gap readjustment in it's installed condition. Thus giving a greater lifetime of the wear affected components.

The units designed for Start-Stop-operation considerably reduce the energy consumption due to a continuously running drive.

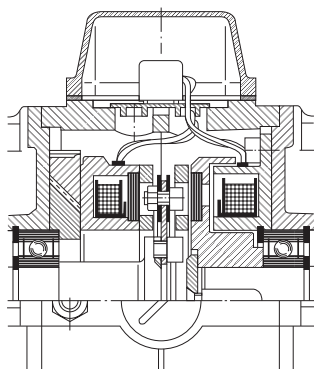
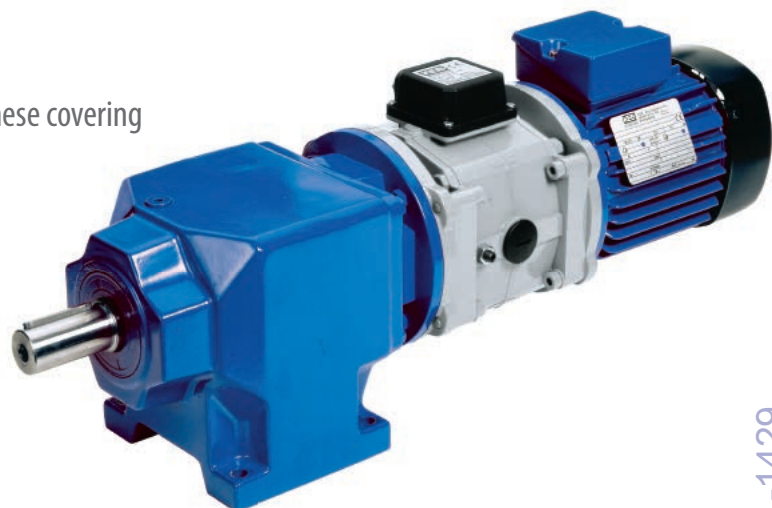

Type 10

has an **energise to engage single sided brake**, this is the most commonly used, permitting high switching frequency and good positioning accuracy. The **COMBITRON** rapid switch can be used with this variant to achieve expectonally high switching frequencies.

The rated torque of both clutch and brake are identical.

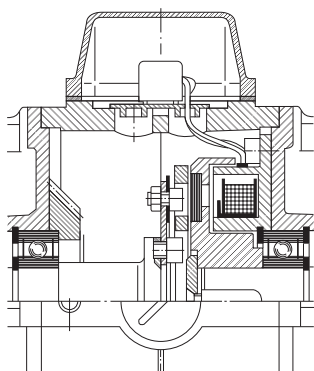

Type 09

is the **COMBIBOX** version **without brake**, i.e. an electrical clutch in a housing for the use between e.g. motor and gear unit.

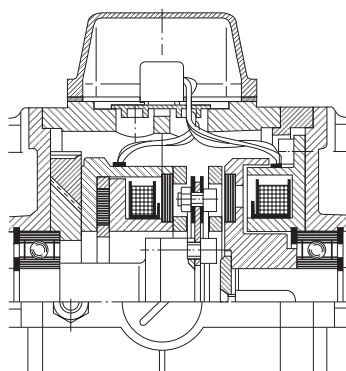

Type 06

has an **energise to disengage permanent magnet single-side brake**. The characteristic of this variant is that the position of the output shaft is kept safe and backlash-free in currentless condition. The rated torque of the brake is slightly lower than that of the clutch.

COMBIBOX shaft in / shaft out

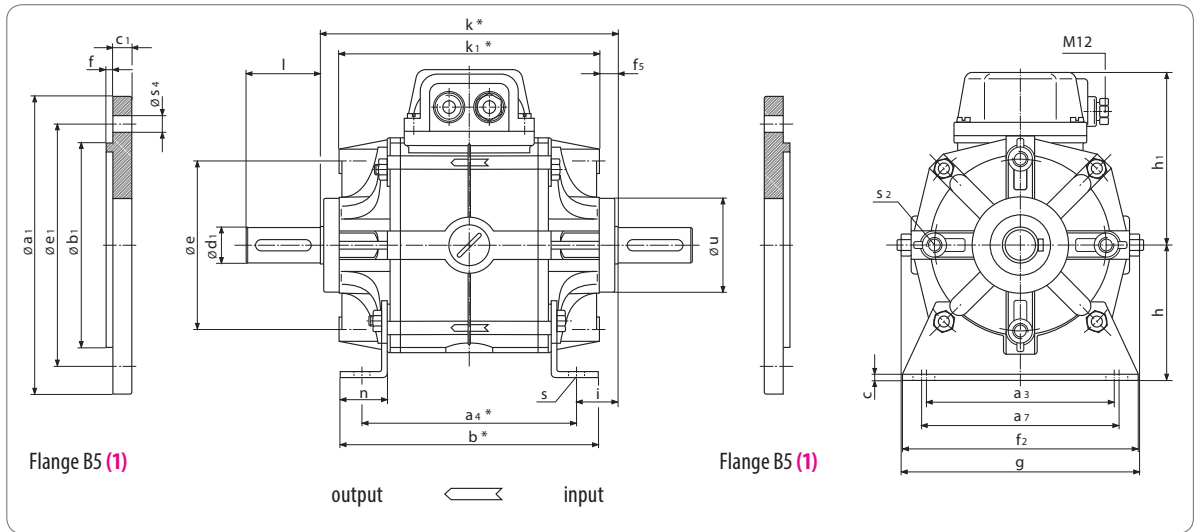

Flange dimensions page 43

Size	a ₃	a ₄	a ₇	b	c	e	f ₂	f ₅	g	h	h ₁	i	k	k ₁	n	s	s ₂	u	Shaft		Weight [kg]
																			d ₁	l	
06	80	100/109	85	115/124	3	72	100	10	103	63	87	18.4	137/146	117/126	18	7	M6	44	11 14	23 30	2.8/2.9
07	105	115/125	110	138/148	3	90	130	10	125	71	94	22.7	160/170	140/150	25	9	M8	50	14 19	30 40	3.9/4.1
08	130	135/147	140	160/172	4	112	160	12	158	90	108	30.6	196/208	172/184	28	9	M8	62	19 24	40 50	7.7/8.7
09	150	155/169	160	180/194	5	137	180	14	185	100	129	34.4	224/238	196/210	30	11	M10	74	24 28	50 60	12.5/15.0
10	185	185/202	195	215/232	6	175	223	18	236	132	154	50.6	286/303	250/267	38	13	M12	95	28	60	22.5/28.0
11	upon request																				

all dimensions in mm keyways according to DIN 6885/1 centerings D according DIN 332/2 Standard voltage 24 V DC VDE 0580, ISO-class „B“

Rated torques type 10 / 09 / 06

	Size	06	07	08	09	10	11
M _{2N} ¹⁾ [Nm]	Clutch	7	15	30	65	130	250 / -
	Brake	7 / 6	15 / 12	30 / 24	65 / 50	130 / 120	250 / -
P ₂₀ [W]	Clutch	15	20	28	35	50	68 / -
	Brake	12 / 13	16 / 21	21 / 20	28 / 30	38 / 50	50 / -

¹⁾ rated torque after running in process

variations type 06 (marked in red)

Part no.	feet	input flange B5 (1)	output flange B5 (1)
-----360			
-----370	X		
-----380		X	
-----390	X	X	
-----410		X	X
-----430	X	X	X
-----570			X
-----580	X		X
Design Type Size			

Ordering example:

Size 06 10 430 Design

Type

V DC, $\varnothing a_r$, $\varnothing d_1$?

Ordering specification:

- part number
- diameter of input-side flange
- diameter of input-side shaft
- diameter of output-side bore
- diameter of output-side flange
- operating voltage of COMBIBOX
- flange dimensions on page 43

COMBIBOX

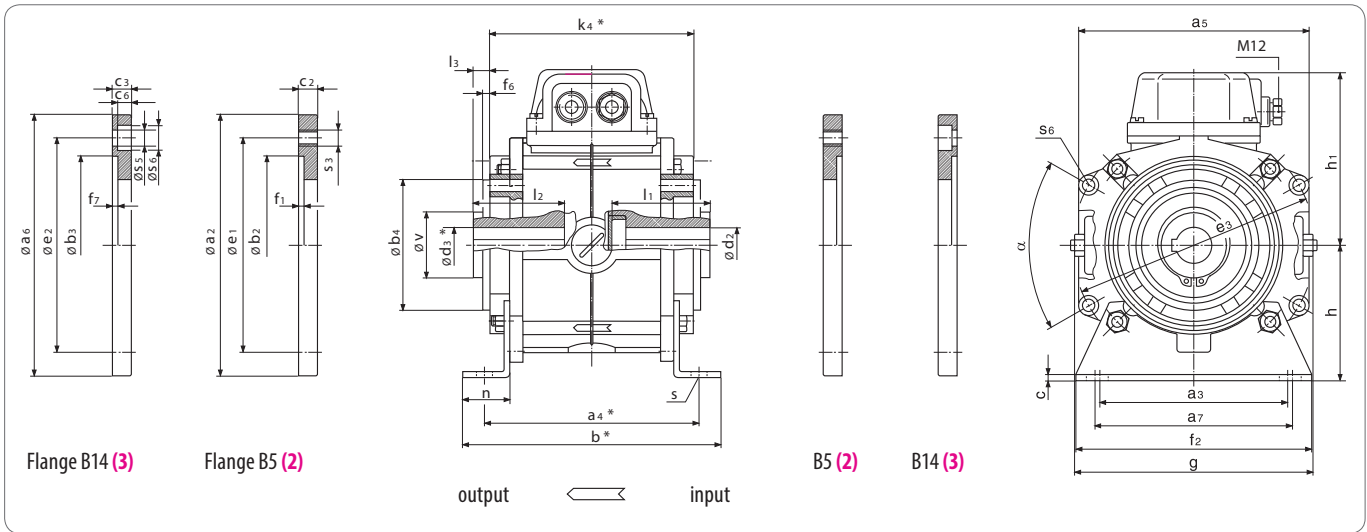

Flange dimensions page 43

Size	a_3	a_4	a_5	a_7	b	b_4 h8	c	d_2 G7 _{max}	d_3 G7 _{max}	e_3	f_2	f_6	Preferential-bore d_2 and d_3
06	80	100 / 109	104	85	115 / 124	60	3	15	15	108	100	4	11 or 14
07	105	115 / 125	123	110	138 / 148	70	3	24	24	128	130	4	14 or 19
08	130	135 / 147	155	140	160 / 172	80	4	28	28	165	160	4	19 or 24
09	150	155 / 169	178	160	180 / 194	95	5	35	35	190	180	5	24 or 28
10	185	185 / 202	229	195	215 / 232	110	6	42	42	242	223	5	28
11	upon request												

all dimensions in mm keyways according to DIN 6885/1 centerings D according DIN 332/2 Standard voltage 24 V DC VDE 0580, ISO-class „B“

Size	g	h	h_1	k_4	l_1	l_2	l_3	n	s	s_6	v	α	Weight [kg]
06	103	63	87	101 / 110	50	57	9	18	7	5.5	30	60	2.7 / 3.1
07	125	71	94	108 / 118	52	61	9	25	9	6.5	35	60	3.7 / 4.5
08	158	90	108	132 / 144	63.5	75	11	28	9	8.5	45	64	7.5 / 8.9
09	185	100	129	153 / 167	74	86	13	30	11	8.5	50	62	12.0 / 14.5
10	236	132	154	175 / 192	86	102	17	38	13	10.5	70	60	20 / 25.5
11	upon request												

variations type 06 (marked in red)

Part no.	feet	input flange		output flange	
		B5 (2)	B14 (3)	B5 (2)	B14 (3)
510			X	X	
520		X		X	
590			X		X
600	X		X		X
610		X			X
680					
690	X				

Design Type Size

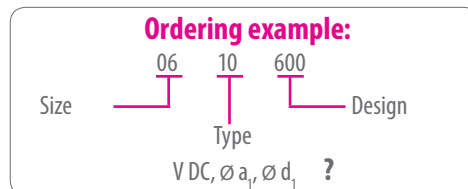

Ordering specification:

- part number
- diameter of input-side flange
- diameter of input-side bore
- diameter of output-side bore
- diameter of output-side flange
- operating voltage of COMBIBOX
- flange dimensions page 43

COMBIBOX bore in / shaft out

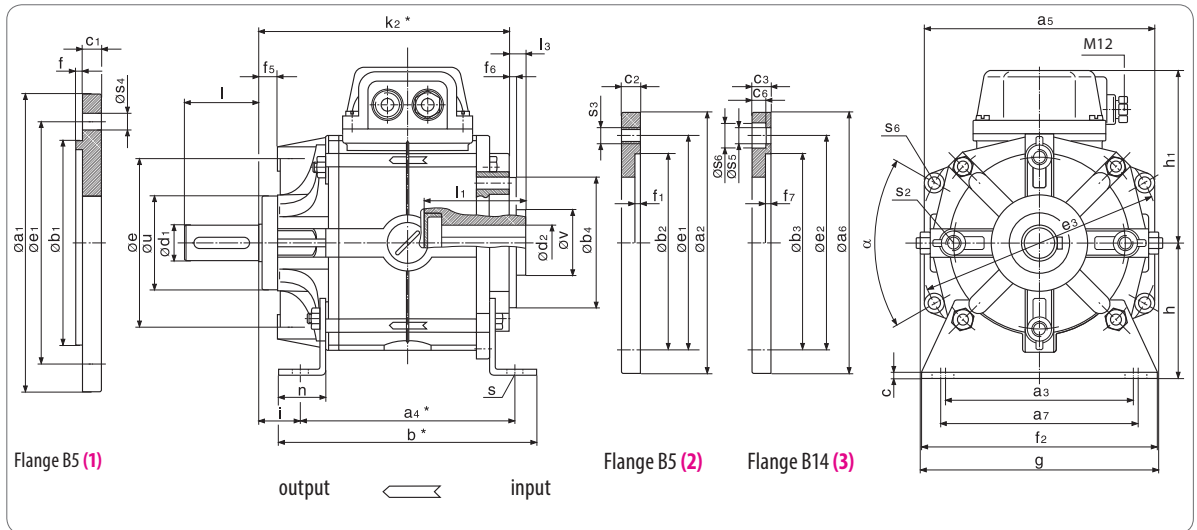

Flange dimensions page 43

Size	a ₃	a ₄	a ₅	a ₇	b	b ₄ h8	c	d ₂₊₃ G7 max	e	e ₃	f ₂	f ₅	f ₆	g	h	h ₁	i
06	80	100/109	104	85	115/124	60	3	15	72	108	100	10	4	103	63	87	18.4
07	105	115/125	123	110	138/148	70	3	24	90	128	130	10	4	125	71	94	22.7
08	130	135/147	155	140	160/172	80	4	28	112	165	160	12	4	158	90	108	30.6
09	150	155/169	178	160	180/194	95	5	35	137	190	180	14	5	185	100	129	34.4
10	185	185/202	229	195	215/232	110	6	42	175	242	223	18	5	236	132	154	50.6
11	upon request																

all dimensions in mm keyways according to DIN 6885/1 centerings D according DIN 332/2 Standard voltage 24 V DC VDE 0580, ISO-class „B“

Rated torques type 10 / 09 / 06

	Size	06	07	08	09	10	11
M _{2N} ¹⁾ [Nm]	Clutch	7	15	30	65	130	250 / -
	Brake	7 / 6	15 / 12	30 / 24	65 / 50	130 / 120	250 / -
P ₂₀ [W]	Clutch	15	20	28	35	50	68 / -
	Brake	12 / 13	16 / 21	21 / 20	28 / 30	38 / 50	50 / -

¹⁾ rated torque after running in process

Part no.	feet	input flange		output flange
		B5 (2)	B14 (3)	B5 (1)
-----440		X		
-----450			X	X
-----460			X	
-----470	X		X	
-----480	X		X	X
-----640				
-----660	X			
-----670		X		X

Design Type Size

Ordering example:

Size 06 10 450 Design

Type

V DC, ∅ a₆, ∅ a₁, ∅ d₁ ?

Ordering specification:

- part number
- diameter of input-side flange
- diameter of input-side bore
- diameter of output-side shaft
- diameter of output-side flange
- operating voltage of COMBIBOX
- flange dimensions on page 43

COMBIBOX

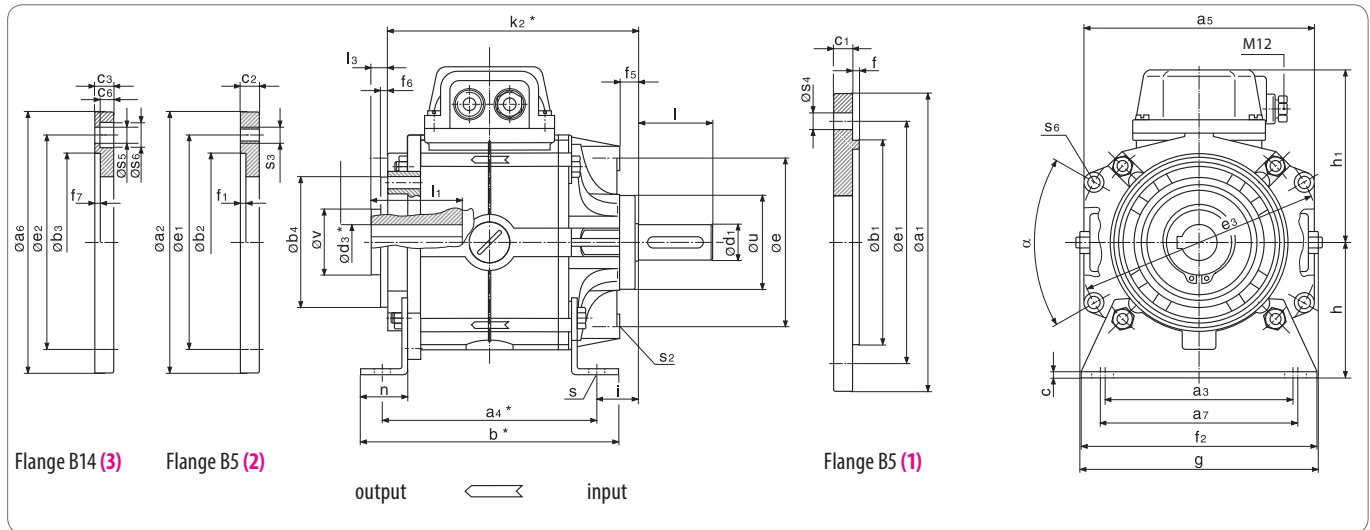

Flange dimensions page 43

k_2	l_1	l_3	n	s	s_2	s_6	u h8	v	α	Preferential bore	Shaft		Weight
										d_2 and d_3	d_1 k6	l	[kg]
119/128	50	9	18	7	M6	5.5	44	30	60	11 or 14	11 14	23 30	2.8/3.1
134/144	52	9	25	9	M8	6.5	50	35	60	14 or 19	14 19	30 40	3.9/4.5
164/176	63.5	11	28	9	M8	8.5	62	45	64	19 or 24	19 24	40 50	7.7/8.9
189/203	74	13	30	11	M10	8.5	74	50	62	24 or 28	24 28	50 60	12.5/14.5
231/248	86	17	38	13	M12	10.5	95	70	60	28	28	60	22.5/26.0

variations type 06 (marked in red)

Part no.	feet	input flange	output flange	
		B5 (1)	B5 (2)	B14 (3)
-----490			X	
-----500		X	X	
-----530				X
-----540	X			X
-----550		X		X
-----560	X	X		X
-----620				
-----630	X			

Design
Type
Size

Ordering example:

Size 06 10 500 Design

Type
V DC, $\varnothing a_1$, $\varnothing d_1$, $\varnothing a_2$, $\varnothing d_3$?

Ordering specification:

- part number
- diameter of input-side flange
- diameter of input-side shaft
- diameter of output-side bore
- diameter of output-side flange
- operating voltage of COMBIBOX
- flange dimensions on page 43

Combibox 06 / 09 / 10				06	07	08	09	10	11
Size	Type	Type							
$M_{2N}^{2)}$	Clutch	06/09/10	[Nm]	7	15	30	65	130	250
	Brake	10		7	15	30	65	130	250
		06		6	12	24	50	120	
P_{20}	Clutch	06/09/10	[W]	15	20	28	35	50	68
	Brake	10		12	16	21	28	38	50
		06		13	21	20	30	50	
$J^{1)}$	Rotor	06/09/10	$[10^{-4}kgm^2]$	1.07	2.98	7.78	23.29	67.4	220
	Armature	06/10		0.84	2.62	8.59	23.08	91.07	330
	Armature	09		0.80	1.2	4.8	12.61	54.3	190
W_{Rmax}		06/09/10	$[10^3J]$	1.9	3.1	4.8	7.5	12.5	20.0
$W_{R0.1mm}$	Clutch	06/09/10	$[10^6J]$	9.5	16.3	25.3	40.9	66.6	104
	Brake	06/10		9.5	16.3	25.3	40.9	66.6	104
P_{Rmax}	Clutch	06/09/10	[J/s]	81	114	161	228	323	458
	Brake	06/10		59	80	114	164	236	339
X		06/09/10	[mm]	0.2	0.3	0.35	0.35	0.4	0.5
X_n		06/09/10	[mm]	0.4	0.6	0.7	0.7	0.8	1.0
n_{max}		06/09/10	[rpm]	3,000	3,000	3,000	3,000	3,000	3,000

Switching times		Type 09/10 rated voltage [ms]				Type 06 rated voltage [ms]			
Clutch		t_{11}	t_1	t_2		t_{11}	t_1	t_2	
Brake			t_2	t_{11}	t_1	t_{11}		t_2	t_1
Size	06	18	55	15	45	20	50	10	45
	07	25	95	20	60	25	85	14	50
	08	40	125	30	110	40	100	22	68
	09	50	200	40	160	50	200	30	150
	10	60	250	45	220	85	250	40	180
	11	100	300	80	260				

- $J^{1)}$ = moment of inertia [kgm²]
- $M_{2N}^{2)}$ = rated torque after running in process [Nm]
- P_R = permissible friction per second [J/s]
- P_{20} = power input at 20 °C [W]
- W_R = friction [J]
- $W_{R0.1}$ = friction work until an abrasion of 0,1 mm is reached [J]
- X = rated air gap [mm]
- X_n = clearance at which a readjustment is recommende [mm]
- t_1 = Engaging time, time until 0.9 M_{2N} is reached [ms]
- t_{11} = Engaging delay time, time until the armature is attracted [ms]
- t_2 = Release time, time until the armature is attracted to the opposing side. [ms]

¹⁾ Sum of the moment of inertia reduced to the speed of the **COMBIBOX** plus the moment of inertia of the **COMBIBOX** parts to be accelerated or decelerated (J).
²⁾ The rated torques listed are safely attained after a run-in phase at 100 rpm. In new condition and for substantially higher speeds the torques are possibly lower.

Power supply

COMBIBOX requires d.c. voltage for actuation. The rated voltage of the magnets is 24 V DC standard. For operation with rectifiers the magnets are available in other voltages on specification. The permanent-magnet brake installed in type 06 requires a smoothed supply voltage. To ensure a safe function in case of large temperature fluctuations, we recommend the supply of the coil with constant current. Single-way or bridge rectifiers of the series COMBITRON 91 can be installed in the terminal box. Trafo rectifiers, electronic switches and rapid switches are also available.

Size	IEC Ø ¹⁾	a1 (1)	a2 (2)	a6 (3)	b1 (1) h8	b2 (2) +0.3 +0.2	b3 (3) H8	c1 (1)	c2 (2)	c3 (3)	c6 (3)
06	90	90	105	105	60	60	60	10	10	10	5.5
	105	105	105	105	70	70	70	10	10	10	6.5
	120	120	120	120	80	80	80	10	10	10	6.5
	140	140	140	140	95	95	95	10	10	12	8.0
	160	160	160	160	110	110	110	10	12	12	8.0
07	105	110	120	120	70	70	70	10	10	10	6.5
	120	120	120	120	80	80	80	10	10	10	6.5
	140	140	140	140	95	95	95	10	10	10	6.0
	160	160	160		110	110		10	12		6.0
	200	200	200		130	130		10	14		8.0
08	120	130	-	160	80		80	12		12	6.5
	140	140	160	160	95	95	95	12	12	12	6.0
	160	160	160	160	110	110	110	12	12	12	6.0
	200	200	200	200	130	130	130	12	14	14	7.0
	250	250	250	-	180	180		12	14		
09	140	160	160	160	95	95	95	14	14	14	9.0
	160	160	160	160	110	110	110	14	14	14	9.0
	200	200	200	200	130	130	130	14	14	14	
	250	250	250	250	180	180	180	14	14	14	
10	160	-	200	200		110	110		18	18	9.0
	200	210	200	200	130	130	130	18	18	18	8.0
	250	250	250		180	180		18	18		
	300	300	300		230	230		18	18		
	350	350			250			20			
11	250	250	268		180	180		20	25		
	300	300	300		230	230		20	25		
	350	350	350		250	250		20	25		
Size	IEC Ø ¹⁾	e1 (1+2)	e2 (3)	f (1)	f1 (2)	f7 (3)	s3 (2)	s4 (1)	s5(3)	s6 (3)	Weight (1/2/3) [kg]
06	90	75	75	2.5	3	3	M5	5.5	5.5	10	0.16
	105	85	85	2.5	3.5	3	M6	7.0	6.5	11	0.17
	120	100	100	3	3.5	3.5	M6	6.5	6.5	11	0.2
	140	115	115	3	3.5	3.5	M8	9	8.5	14	0.28
	160	130	130	3.5	4	4	M8	9	8.5	14	0.45
07	105	85	85	2.5	3.5	3	M6	M6	6.5	11	0.21
	120	100	100	3	3.5	3.5	M6	6.5	6.5	11	0.22
	140	115	115	3	3.5	3.5	M8	9	9	14	0.3
	160	130		3.5	4		M8	9		14	0.33
	200	165		3.5	4		M10	11		18	0.55
08	120	100	100	3		3.5		7	6.5	11	0.45
	140	115	115	3	3.5	3.5	M8	9	9	14	0.48
	160	130	130	3.5	4	4	M8	9	9	14	0.5
	200	165	165	3.5	4	4.5	M10	11	14	18	0.8
	250	215	215	4	4.5		M12	14			1.4
09	140	115	115	3		3.5		9	9	15	0.5
	160	130	130	3.5	4	4	M8	9	9	15	0.55
	200	165	165	3.5	4	4	M10	11	11		0.63
	250	215	215	4	4.5	4.5	M12	14	14		0.95
10	160		130		4.5	4.5	M8		9	15	0.9
	200	165	165	4	4.5	4	M10	11	11	18	1.1
	250	215		4	4.5		M12	14			1.2
	300	265		4	5		M12	14			1.25
	350	300		5				18			6.5
11	250	215		4	4.5		M12	14			
	300	265		4	4.5		M12	14			
	350	300		5	5.5		M16	18			

¹⁾ according DIN IEC 34

standard flange

COMBITRON are supply and actuator modules for the electromagnet clutches and brakes. As power supply for DC- or AC-side switching different single-wave and bridge rectifiers as well as rapid switchgear of the series **COMBITRON** are available.

The rectifiers correspond to the low voltage regulation 73/231/EWG of the European Union.

COMBITRON Rectifiers and Switches

Half-wave and bridge rectifiers from	0 ... 720 V AC	page 44	COMBITRON 91
Electronic rapid switch up to	50 W	page 46	COMBITRON 94
Rapid-switching rectifier (for COMBISTOP)		page 47	COMBITRON 98

Technical Data

Switching mode (AC- / DC-side switching)	page 48
--	---------



COMBITRON 91 are **rectifiers** for power supply of brakes and clutches. AC voltage supply max 720 V AC for AC or DC side switching conform to the low voltage regulation 72/231 EWG of the European Union.

Harmful electromagnetic interferences arise at the switching of electromagnetic clutches and brakes and other inductive DC consumers.

The half-wave rectifier 0291010-CEMV limits these interferences to class A according to EN 55011.

All other rectifiers are not equipped with measurements to suppress radio interference. This has to be taken into consideration for the planning of the interference suppression of the plant or the machine. The user is responsible for meeting the EU machine directive.

U_{in} switching U_{vmax}	275 V AC +0% AC/DC 450 V	500 V AC +0% AC/DC 900 V	600 V AC +0% AC 1000 V	720 V AC +0% AC 1600 V
half wave ⁴⁾ $U_{out} = 0,45 * U_{in}$ $I_N (45^\circ C) = 1,0A$ $I_N (80^\circ C) = 0,5A$	0291010-CE07 ²⁾ 	0491010-CE07 ³⁾ 	0591010-CE09 ²⁾ 	0691010-CE09 ³⁾
full wave ⁴⁾ $U_{out} = 0,9 * U_{in}$ $I_N (45^\circ C) = 2,0A$ $I_N (80^\circ C) = 1,0A$	0291020-CE07 ²⁾ 	0491020-CE07 ³⁾ 	U_{in} maximum input voltage U_{vmax} maximum cut-off voltage U_{out} Output DC voltage AC AC switching DC DC-side switching $I_N (45^\circ C)$ Rated output current at the temperature	
half wave with EMC protection ¹⁾ $U_{out} = 0,45 * U_{in}$ $I_N (45^\circ C) = 1,0A$ $I_N (80^\circ C) = 0,5A$	0291010-CEMV ³⁾ 	Characteristics <ul style="list-style-type: none"> UL - certification (No.: E.308765) compact design in a plastic housing possible installation into the motor terminal box protection against voltage peaks of the switching contacts maximal ambient temperature 80 °C 		

¹⁾ with internal interference suppression according to EN 55011/ class A
²⁾ picture 1 ³⁾ picture 2
⁴⁾ different values (U, A) when used under UL conditions

Nominal voltage magnet	Coil voltage tolerance $U_2 (U_{out})$	AC voltage supply $U_1 (U_{in})$	Type of rectifier	
24 V DC				
105 V DC	93 - 118	230 V AC	half wave rectifier	(0291010-CE07)
205 V DC	182 - 230	230 V AC	full wave rectifier	(0291020-CE07)
180 V DC	162 - 198	400 V AC	half wave rectifier	(0491010-CE07)

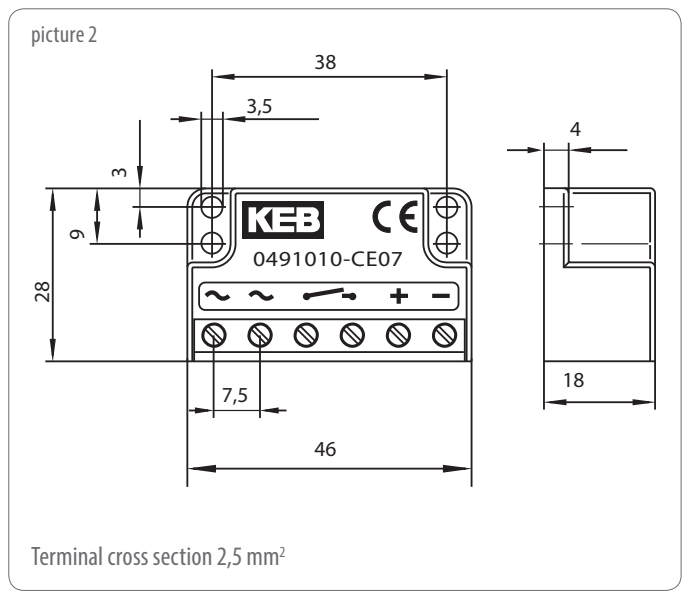
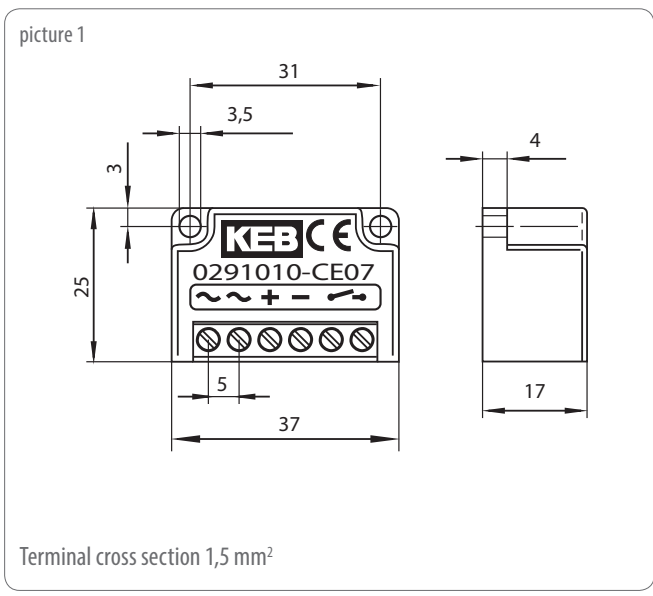

COMBITRON 94 for the power supply / actuator of two consumers.

The output current control ensures a constant magnetic flux and permits short-time overexcitations for shorter switching processes, i.e. improved repeat accuracy. The main field of application is the interconnection of clutch-brake-combinations **COMBIBOX** and is used whenever high switching frequencies and positioning accuracy are demanded. The primary feature is the current regulation of 24 V DC supply of electromagnets.

Eigenschaften

- circuit board is supplied inclusive holder and slide-in device
- connection according to DIN 41612
- Vadjustment of the deceleration time by potentiometer from 0 ... 1 second
- power supply of the circuit board via separate transformer
input voltage: 230/400/460 V AC
- power range 15 ... 50 W
- digital inputs
- relay output

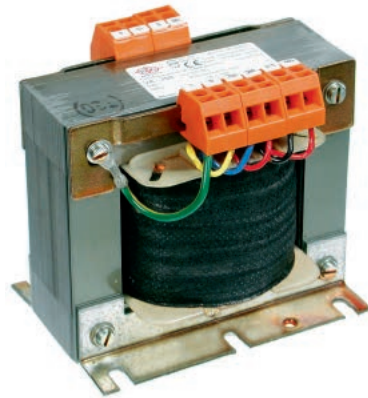

transformer 0094006-0100



switcher 0094006-0004

COMBITRON 98 rapid-switching rectifiers with overexcitation for optimal turn-on and turn-off times of spring-applied brakes and electromagnets.

Two Powerbox versions with similar right housing to fit on DIN rail or bolt on version.

COMBITRON 9098200-CE09 UL - certification (No.: E.308765)



	9098210-CE04	9098200-CE09 ¹⁾
Input voltage	24 V DC $\pm 20\%$	180-300 V AC $\pm 0\%$
Overexcitation time	800 ms $\pm 15\%$	350 ms $\pm 10\%$
Cable length	max. 10 m to brake coil	max. 100 m to brake coil
Current I _N 45 °C	1.2 A continuous 7 A for 800 ms	1.2 A continuous 2.4 A for 350 ms
Current I _N 75 °C	0.6 A continuous 3.5 A for 800 ms	0.7 A continuous 1.4 A for 350 ms
Temperature	CCV -40° ... 75°	CCV -40° ... 75°
Switching rate	max. 6 per minute at max current	max. 1 per minute at max current
Side altitude above sea level	> 1,000 m - 1 % current reduction/100 m	> 1,000 m - 1 % current reduction/100 m
Wiring diagrams		

¹⁾ different values (U, A) when used under conditions of UL

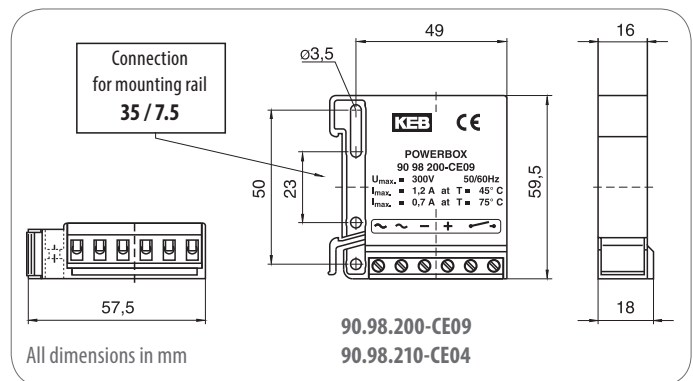

AC-side Switching

When switching before the rectifier on the AC-side the magnetic field decays slowly. At this mode of switching the tripping delay is quite long. The AC-side switching requires no protective measurements for the coil and the switching contacts. On disconnection the rectifier diodes act as free-wheeling diodes.

The switching times t_{11} for AC-side switching increase when the rectifier is connected directly in the motor terminal box **(2)**. When the motor slows down a generatoric voltage is applied to the motor terminals. The wiring **(2 and 3)** is not permitted for frequency inverter operation.

For line lengths of more than 10 m between rectifier and brake at AC-side switching the regulations prescribe the use of a separate switch **(1)**. In this case the supply voltage may not be tapped behind the motor contactor **(2)**. If it is not possible to install an additional switch the use of special rectifiers becomes necessary.

Current-time-/Voltage-time-/Torque-time-diagram

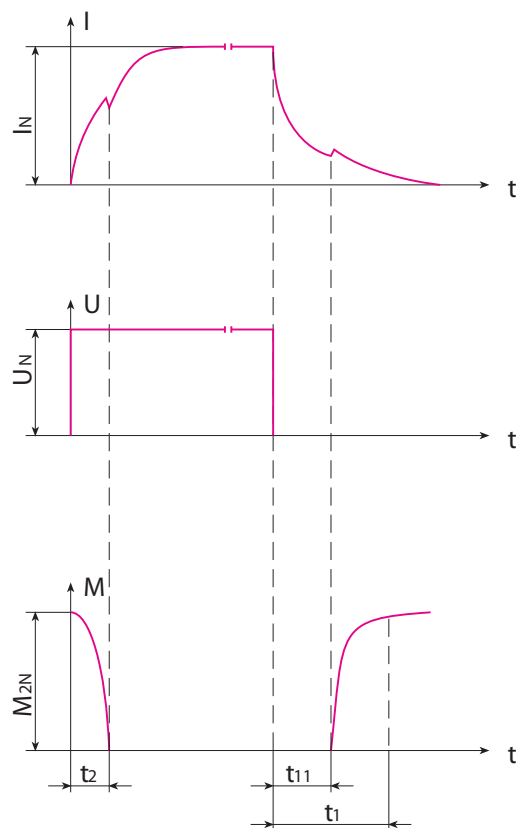

t_1 = Engagement time
 t_{11} = Engagement delay time
 t_2 = Release time

Wiring diagram

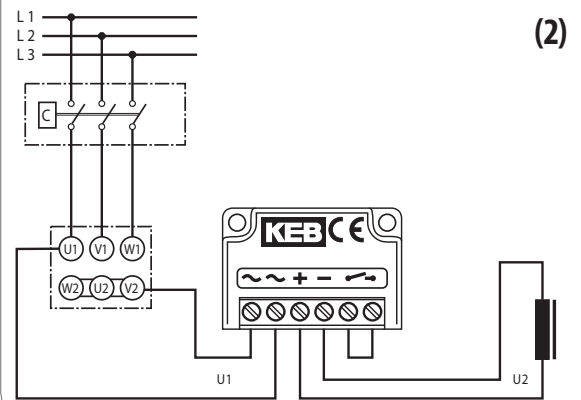
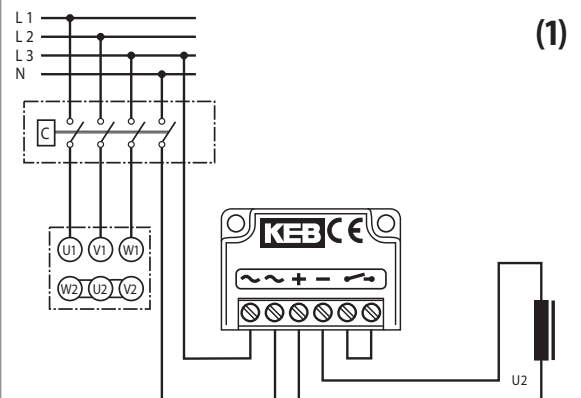

DC-side switching

The switching is done between the rectifier and the magnet. At this mode of switching the tripping delay is short, since the energy of the magnetic field is absorbed by the rectifier. The voltage peaks that occur at switching are limited to a harmless level for the rectifier.

The maximal permissible switching frequency for the DC-side switching of rectifiers depends on the energy content of the magnet for **COMBISTOP**. Higher switching frequencies are achieved by the external connection of a varistor in parallel to the brake or to the terminals + and - DC of the rectifier.

Rectifier	KEB-article	varistor
0291	0090045-2753	S20K275
0491	0090045-6251	S20K625
0591	0090045-6251	S20K625

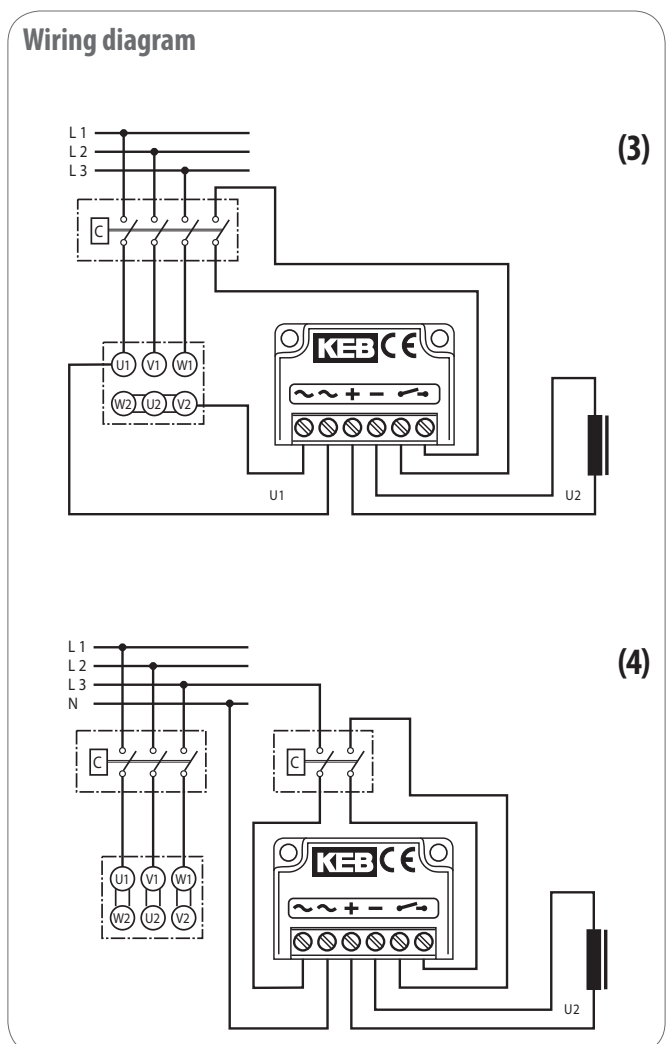
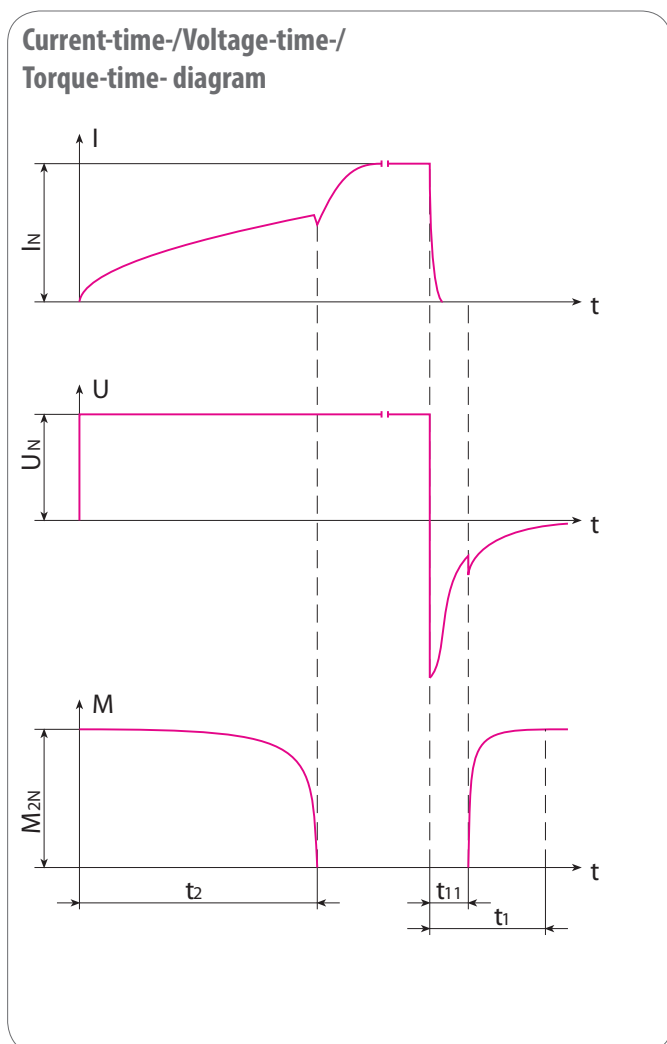

The simultaneous AC and DC-side switching, shown in example **4** guarantees short disconnecting times and reduces the contact erosion.

Decisive for the dimensioning of the clutches and brakes are the required torque, thermal load, braking time and service life.

Rated Torque M_{2N}

To ensure that brakes and clutches work safely even under extreme conditions, the required torque must be multiplied by a safety factor. The selection of the safety factor depends essentially on the application.

The dynamic torque of a single-disc brake may be substantially lower than the rated torque.

$$M_{2N} = M_{\text{erf}} \cdot K \quad K \geq 2 \quad M_{\text{erf}} = \text{required torque [Nm]}$$

Required torque M_{erf}

The required torque very often is a mixture of dynamic and static load. When choosing the sign take into account whether the load torque supports or counteracts the deceleration.

$$M_{\text{erf}} = M_A \pm M_L$$

$$M_A = J \cdot \alpha$$

Rough definition of the required braking torque

If the mass moment of inertia is unknown and the driving power is fixed then the required braking torque is calculated as follows:

$$M_{\text{erf}} = 9550 \cdot \frac{P}{n}$$

Thermal load

The dimensioning solely on the basis of the required braking torque is permissible only in very few cases. When decelerating the load and the mass moment of inertia is reduced to the brake shaft, the kinetic energy is converted into heat (friction work of the brake). The permissible friction work in dependence on the switching frequency may not be exceeded.

Please note that the maximal permissible friction work is valid only up to the corresponding speed. In case of emergency stop from maximum speed the maximal permissible friction work lies considerably below the values specified in the graphic.

$$W_R = \frac{J \cdot n^2}{182,5} \cdot \frac{M_{2N}}{M_{2N} \pm M_L} \quad W_R \leq W_{R\text{max}}$$

Slip time t_3 [ms]

The time from the beginning of the torque rise until attaining the moment of synchronization.

$$t_3 = 104,6 \cdot \frac{J \cdot \Delta n}{M_{2N} \pm M_L} + t_{11}$$

Service life

The service life depends to a large extent on the peak temperature at braking, which is dependent on the speed, the deceleration time and the current brake torque.

For that reason it is not possible to make universally valid statements with regard to the service life that apply to all operating conditions. Statements to the individual case can be made only when all operating conditions are known. At no time should the friction lining thickness (COMBISTOP) be less than g_{min} .

$$L_N = \frac{(X_n - X) \cdot W_{R0,1}}{0,1 \cdot W_R}$$

Acceleration- / Deceleration time

$$t = \frac{J \cdot \omega}{M_{2N} \pm M_L} + t_1$$

Headquarters

KEB Automation KG

Südstraße 38 • D - 32683 Barntrup
Telefon +49 5263 401-0 • Telefax 401-116
Internet: www.keb.de • E-Mail: info@keb.de



KEB Antriebstechnik GmbH • Geared Motors
Wildbacher Straße 5 • D - 08289 Schneeberg
Telefon +49 3772 67-0 • Telefax 67-281
Internet: www.keb-drive.de • E-Mail: info@keb-drive.de



COMPANIES

AUSTRIA

KEB Antriebstechnik
Austria GmbH
Ritzstraße 8
A - 4614 Marchtrenk
Tel: +43 (0)7243 53586-0
Fax: +43 (0)7243 53586-21
E-Mail: info@keb.at
Internet: www.keb.at

CHINA

KEB Power Transmission
Technology (Shanghai) Co. Ltd.
No. 435 QianPu Road
Songjiang East Industrial Zone
CN-201611 Shanghai, P.R. China
Tel: +86 (0)21 37746688
Fax: +86 (0)21 37746600
E-Mail: info@keb.cn
Internet: www.keb.cn

FRANCE

Société Française KEB
Z.I. de la Croix St. Nicolas
14, rue Gustave Eiffel
F - 94510 LA QUEUE EN BRIE
Tel: +33 (0)149620101
Fax: +33 (0)145767495
E-Mail: info@keb.fr
Internet: www.keb.fr

GREAT BRITAIN

KEB (UK) Ltd.
5 Morris Close
Park Farm, Industrial Estate
GB - Wellingborough
GB - Northants, NN8 6 XF
Tel: +44 1933 402220
Fax: +44 1933 400724
E-Mail: info@keb.co.uk
Internet: www.keb.co.uk

ITALY

KEB Italia S.r.l. Unipersonale
Via Newton, 2
I - 20019 Settimo Milanese (Milano)
Tel: +39 02 3353531
Fax: +39 02 33500790
E-Mail: info@keb.it
Internet: www.keb.it

JAPAN

KEB - Japan Ltd.
15 - 16, 2 - Chome
Takanawa Minato-ku
J - Tokyo 108 - 0074
Tel: +81 (0)33 445-8515
Fax: +81 (0)33 445-8215
E-Mail: info@keb.jp
Internet: www.keb.jp

RUSSIA

KEB CIS ZAO
Lesnaya str, house 30
Dzerzhinsky (MO)
RUS - 140091 Moscow region
Tel: +7 (0)495 6320217
Fax: +7 (0)495 6320217
E-Mail: info@keb.ru
Internet: www.keb.ru

USA

KEB America, Inc
5100 Valley Industrial Blvd. South
USA - Shakopee, MN 55379
Tel: +1 952 2241400
Fax: +1 952 2241499
E-Mail: info@kebameric.com
Internet: www.kebameric.com

Representative offices

- Belgium
- Brazil
- Korea
- Spain

Further partners for ...

Australia • Belgium • Bulgaria • Czech Republic • Denmark • Egypt • Greece • Hungary • India • Indonesia • Iran • Israel • Malaysia • Morocco • Netherlands • New Zealand • Pakistan • Poland • Portugal • Romania • Singapore • Slovakia • South Africa • Spain • Sweden • Switzerland • Taiwan • Thailand • Tunisia • Turkey • Uzbekistan

... under www.keb.de/en/contact/keb-worldwide.html

